



MOBILE AD HOC NETWORKING

Based on Advanced topics in Distributed systems presentation, Mobile Ad hoc Networking, Dr.-In Matthias Hollick, Prof. Dr.-Ing Ralf Steinmetz., 2006.

Ali Zaher

Oslo 30.11.2012

CONTENTS

- Basics about MANET.
- Applications.
- Motivation
- Routing in TCP/IP
- Routing in MANET
 - AODV.
 - LAR.
- Security.
- Q&A.

BASICS ABOUT MANET?

- Historical successor of packet radio networks.
- Self organizing, mobile and wireless nodes.
- Absence of infrastructure.
- Multi-hop routing necessary.
- Systems are both terminals (end systems) and routers (nodes).
- Constraints:
 - Dynamics.
 - Energy.
 - Bandwidth.
 - Link asymmetry.

APPLICATIONS

○ Military applications

- Battlefield communication (soldiers, tanks,...).
- Smart dust (sensor networks to detect chemical or biological threats).



APPLICATIONS

- Civilian Applications:
 - Vehicular environment (telematics, car to car communication, taxi cab network,..).
 - Entertainment (file sharing, gaming, .., in train, car, plane, school,..).
 - Event support (conferences, sport-events, meetings, lectures,...).
 - Home Networking (VCR,DVD, home entertainment,).
 - Disaster recovery (emergency services, ambulance, police).
 - Smart dust (sensor networks for civilian applications)

VEHICLE COMMUNICATION

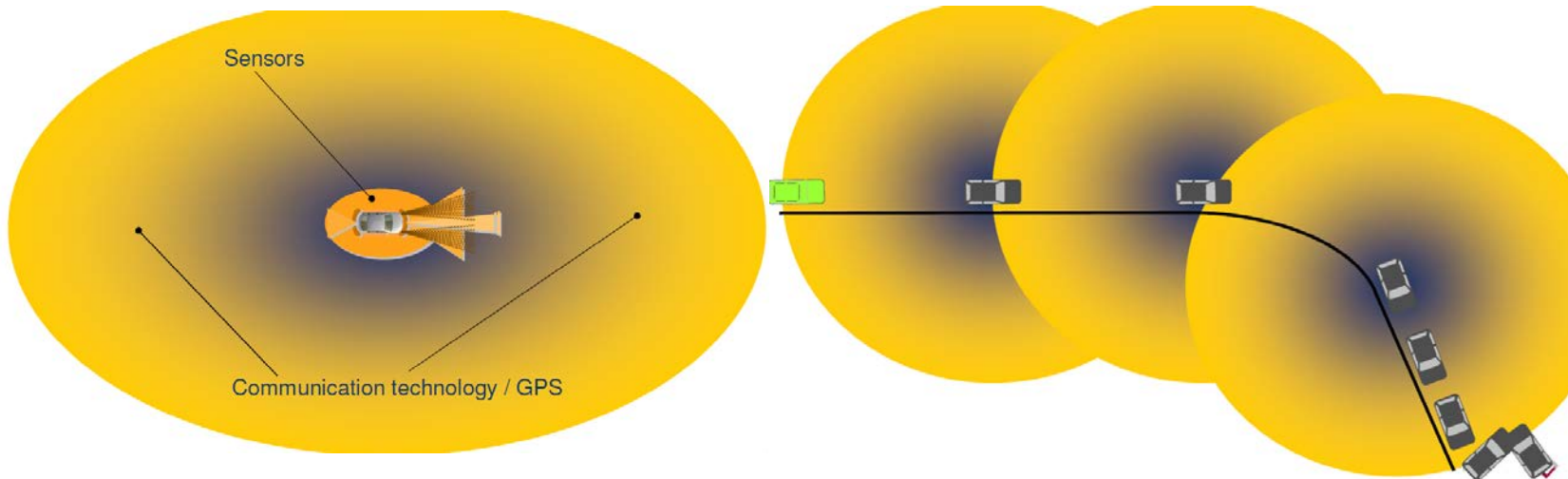
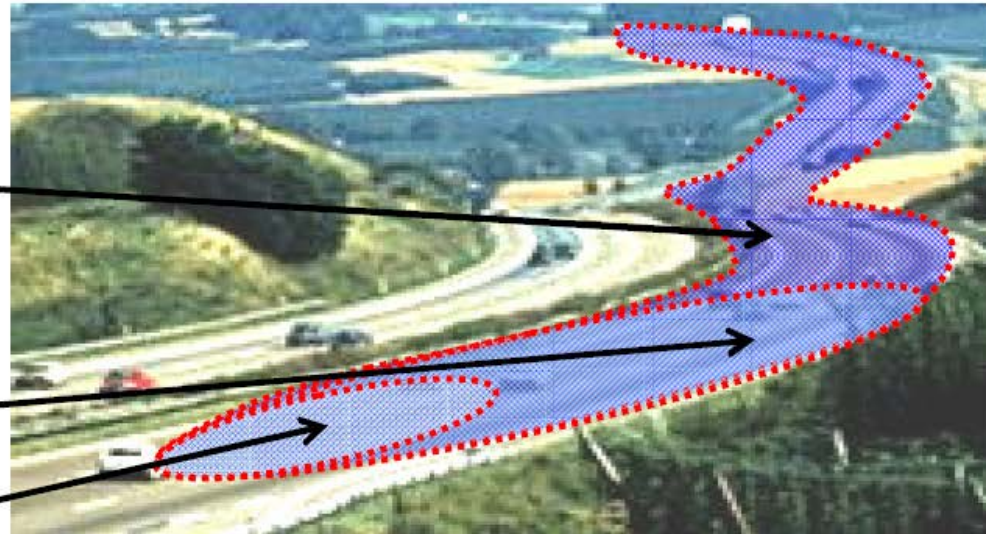

VEHICLE COMMUNICATION

- Physical layer for C2C-CC:
 - IEEE 802.11p (Wireless Access for Vehicular Environment WAVE).
 - Frequency band: 75Mhz around 5.9GHz.
 - Maximum Transmit power: 33dBm.
 - Transmit power control: shall be supported with minimum 3dBm.
 - Data rates: 3, 4.5, 6, 9, 12, 18, 24, 27Mbps. Default 6Mbps.
 - Antenna: Not yet defined (August 2007).
 - Communication mode: Half-duplex and Broadcast.
 - Frequency modulation: OFDM.

MOTIVATION FOR MANET IN A CITY

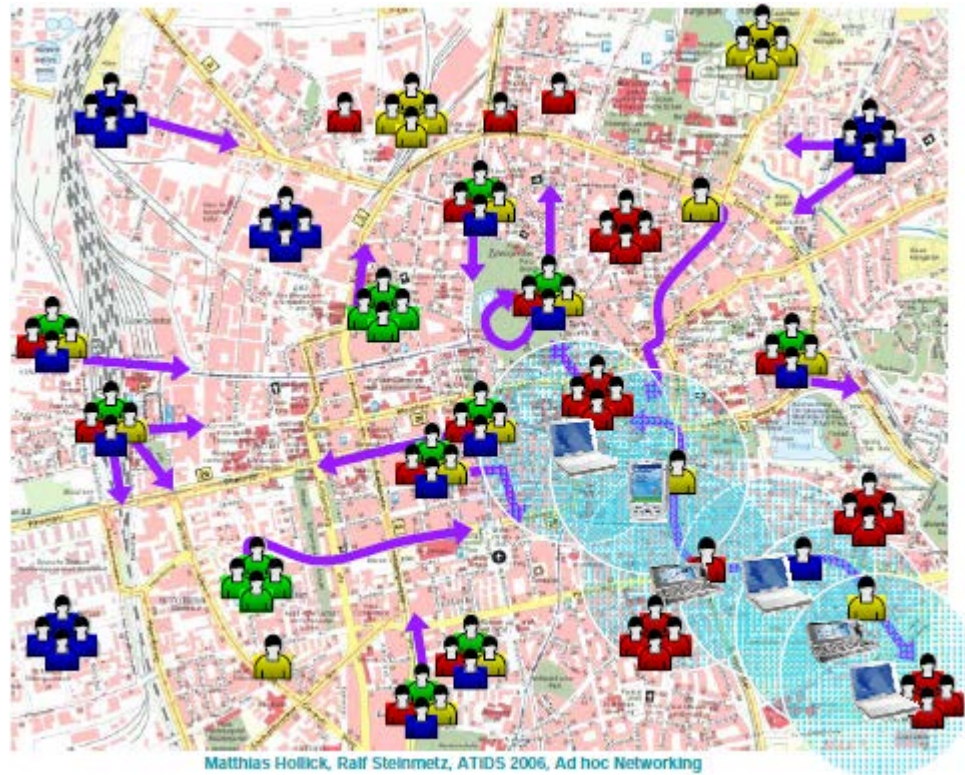

ROUTING

- Routing in TCP/IP

From Computer Desktop Encyclopedia
© 1998 The Computer Language Co. Inc.

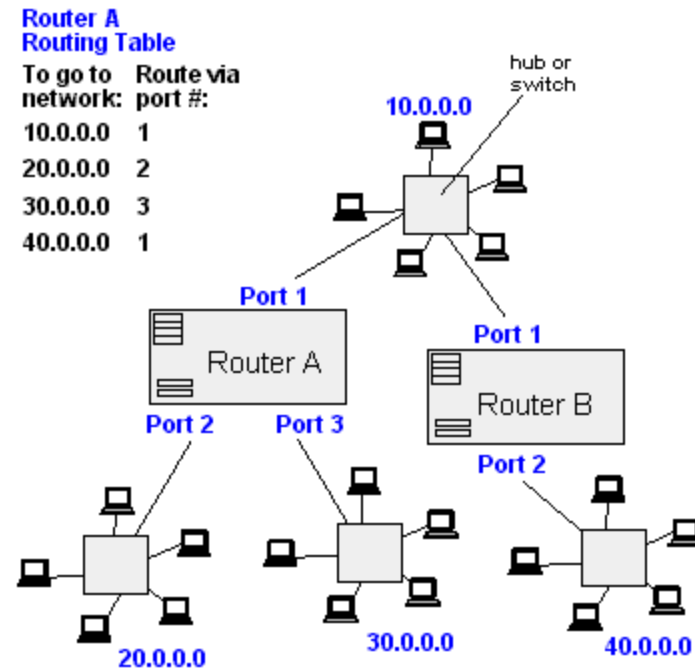

ROUTING IN MANET

- Specialized ad hoc routing:
 - To deal with topology dynamics induced by mobility.
 - To reach nodes that are not direct neighbors.
 - To match the characteristics of wireless communication.
 - To support spontaneous formation of the network.
 - To operate without fixed infrastructure.
 - All end-systems are also acting as routers.
- Some or all are the basis for MANET routing protocols.

ROUTING PROTOCOLS

- Ad hoc On demand Distance Vector Protocol (AODV):
 - All nodes are treated equal.
 - Based on distance vector principle.
 - Route discovery cycle for route finding, using flooding.
 - No overhead on data packets.



ROUTING PROTOCOLS

○ Location-Aided routing (LAR).

- Exploits location information to limit scope of flooding for route requests. (may be obtained from GPS).
- Expected Zone is determined as a region that is expected to hold the current location of the destination node D.
- Only nodes within the request zone forward route requests.

S = Source node, D = Destination node

X = last known location of node D, at time t_0

Y = location of node D at current time t_1 , unknown to sender S

$r = (t_1 - t_0) * \text{estimate of D's speed}$

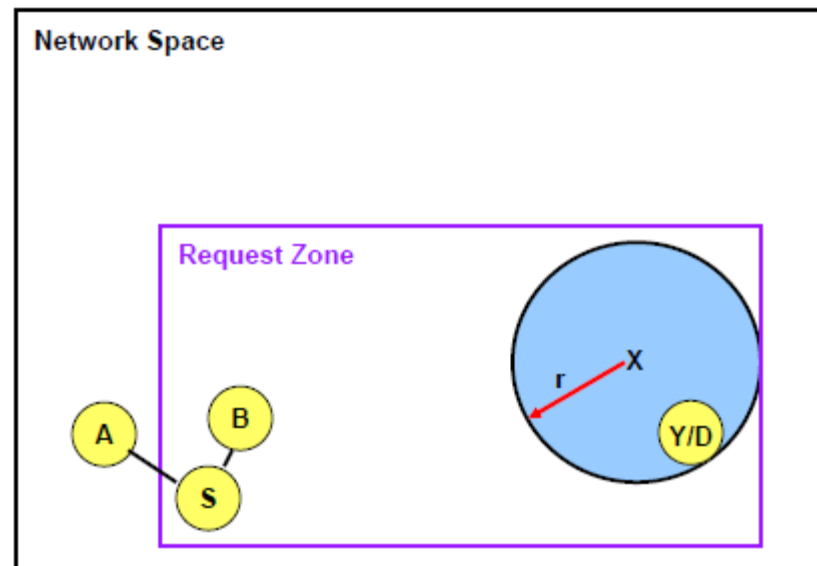

ROUTING PROTOCOLS

- LAR summary- Advantages:
 - Reduces the scope of route request flood.
 - Reduces overhead of route discovery.
- LAR summary- Disadvantages:
 - Nodes need to know their physical locations.
 - Does not take into account possible existence of obstruction for radio transmissions.

SECURITY

- Node misbehavior scenario.

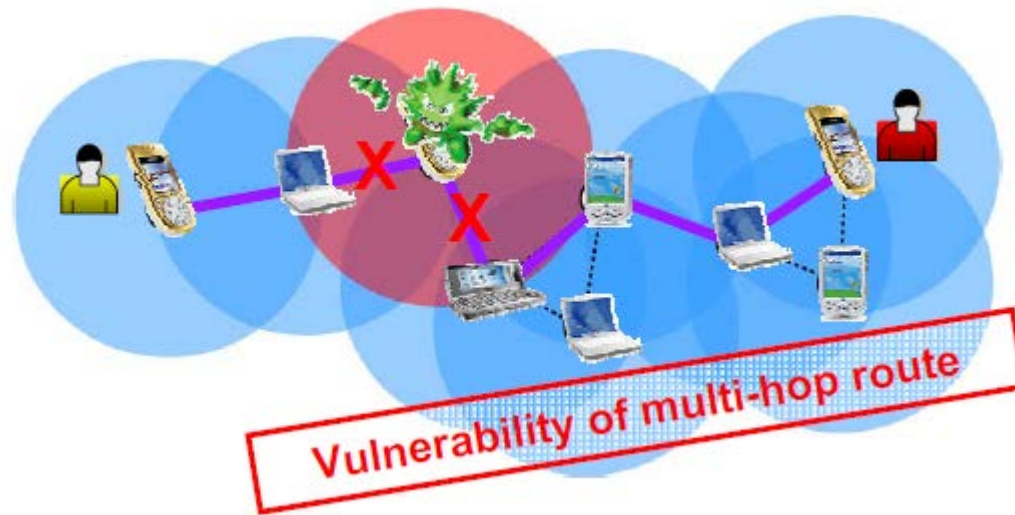

SECURITY

Experiment:

Packet loss, Test (7.2), Low mobility

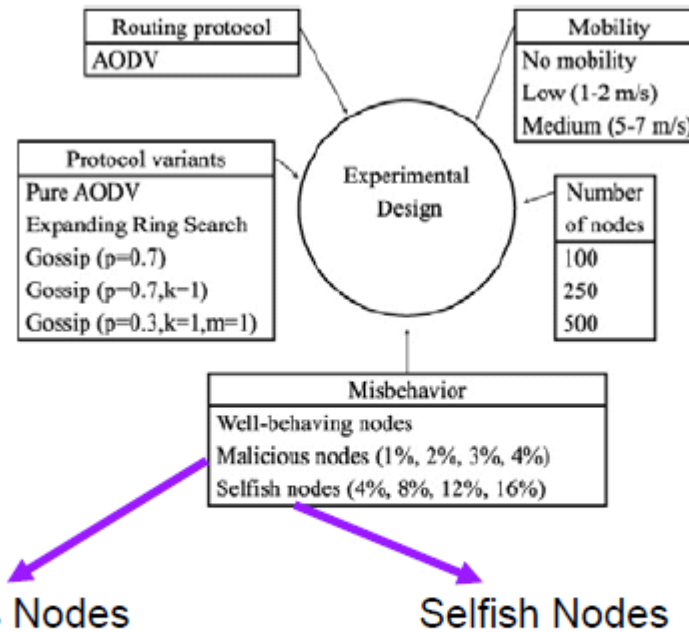
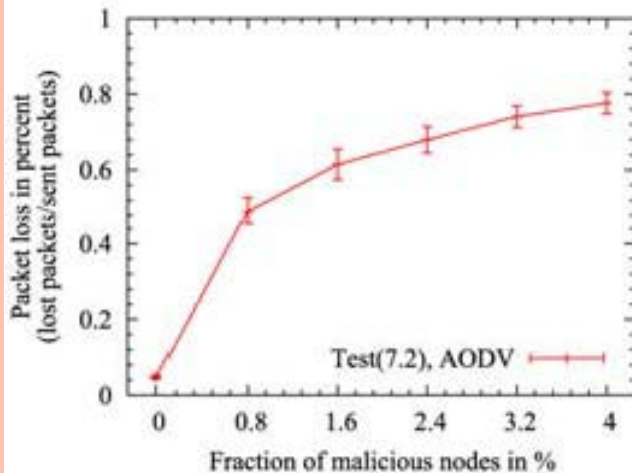
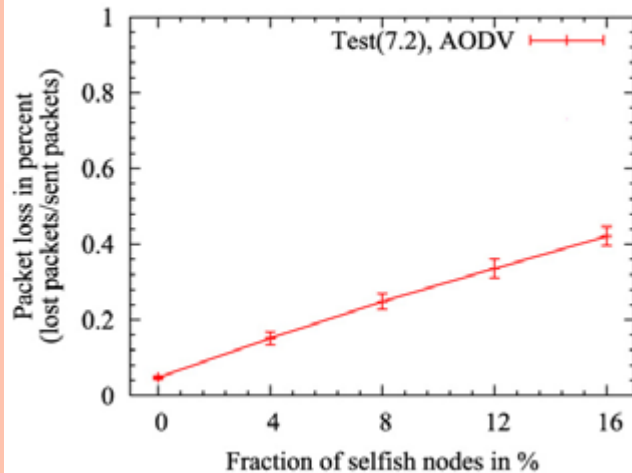

- Inject false information or remove packets from the network (here black holes)
- Optimize their own gain, neglecting welfare of other nodes

Q&A



REFERENCES

1. Advanced topics in Distributed systems, Mobile Ad hoc Networking, Dr.-In Matthias Hollick, Prof. Dr.-Ing Ralf Steinmetz., 2006.
2. Car 2 car communication consortium, Manifesto, Overview of the C2C-CC system, August 2007.