

CELLS AND CELLULAR TRAFFIC

4.0 INTRODUCTION

Mobile systems are designed to operate over a very large geographical area with a limited bandwidth. The service providers use tall antennae and higher transmitted powers to provide coverage over as large an area as possible. However, restrictions exist in different communities for maximum antenna height as well as maximum transmitted power. Once the limiting values of these two parameters have been reached, the only means of providing mobile phone use to an increased number of subscribers is through the use of *cells* (Jake 1974, Lee 1997, MacD 1979, Youn 1979, Oett 1983, Hugh 1985). By dividing a geographical region into smaller-size cells, providers can reuse the channels or frequencies repeatedly and thereby operate with less power. This frequency reuse through the use of cells permits the providers to increase capacity with a limited bandwidth. However, this frequency reuse comes at the expense of co-channel interference (CCI), which is the interference produced by the use of identical channels (frequencies). For example, if a carrier frequency of f_{c1} is used in a cell, as shown in Figure 4.1, it may be used again by cells at a certain radius away from it.

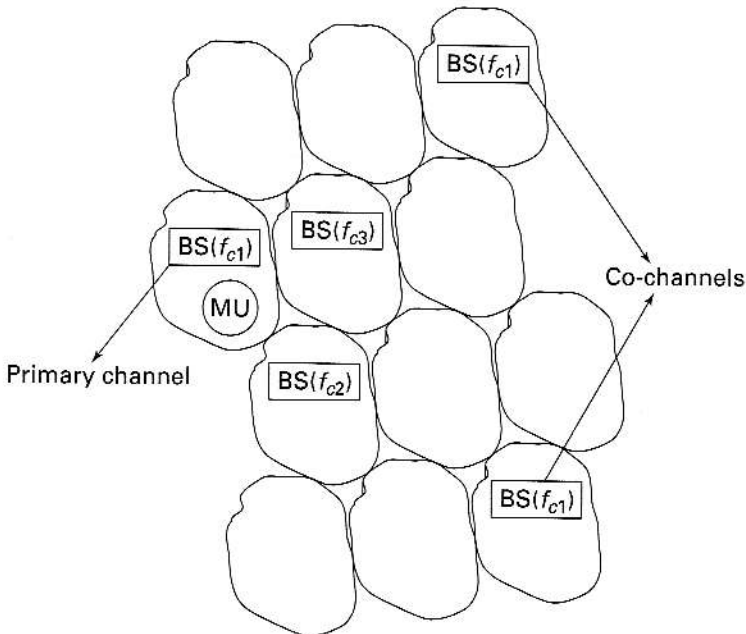

FIGURE 4.1 Splitting of the geographical region into "cells." The frequency f_{c1} is used in multiple cells separated by a fixed distance.

Depending on the distance between the MU and its own base station and the distances between co-channel base stations and the MU, interference from co-channels will be a problem. The unwanted signals generated by other base stations operating at the same frequency band result in co-channel interference. Figure 4.2 shows the power from the primary channel and the total power from co-channels corresponding to the same frequency band. The shaded region shows the relative power of the co-channels. Additional detail on the calculation of CCI is given later in this chapter.

As shown in Figure 4.1, a cell is the smallest geographical area covered by a base station. It can serve a certain number of users depending on the number of channels and the blocking probability. The number of users is the most important factor determining cell size. When the number of users increases, it becomes necessary to reduce the size of the cells so that the channels can be reused more often. Cell splitting, which reduces the size of the cells, also reduces the maximum power that can be transmitted. The reduction in power is necessary to prevent co-channel interference from the channel operating at a distance. A simple way to understand these concepts is to examine the layout of a geographical area covered with cells of symmetric shapes, as shown in Figure 4.3. The ideal shape would be a circle, which makes it possible to define a radial region. However, this will leave a number of "zones" outside the coverage, so the optimal shape of the cell (MacD 1979) is hexagonal, as shown in Figure 4.3*d*. A few other regular shapes, such as triangles and squares, are not well suited since the distance from the center of the cell to different points of the perimeter will be different. A hexagon comes reasonably close to the ideal shape that leaves no gaps and allows only small differences from the center to various points on the perimeter.

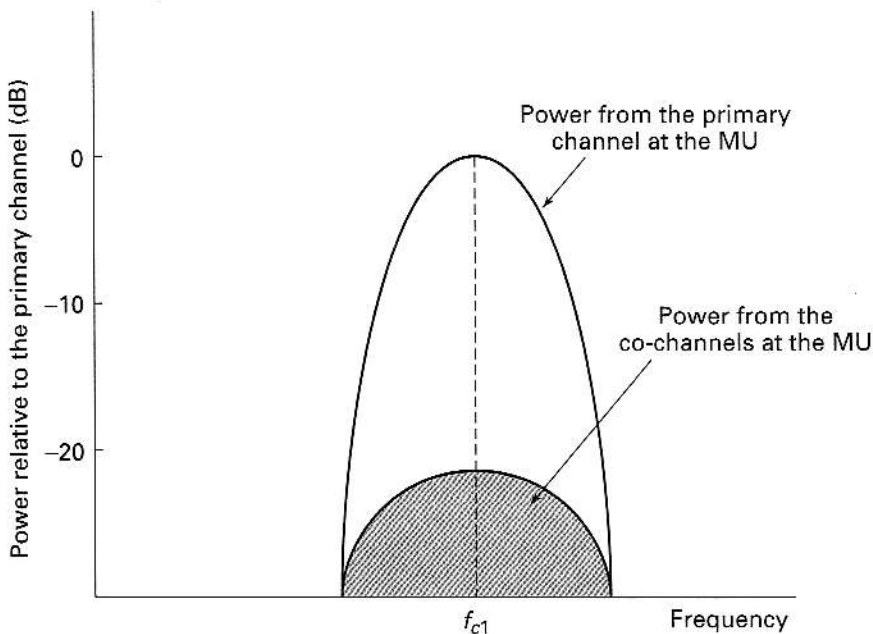

FIGURE 4.2 The power from the primary channel and the total power from the co-channels in the cell subscribing to the primary channel.

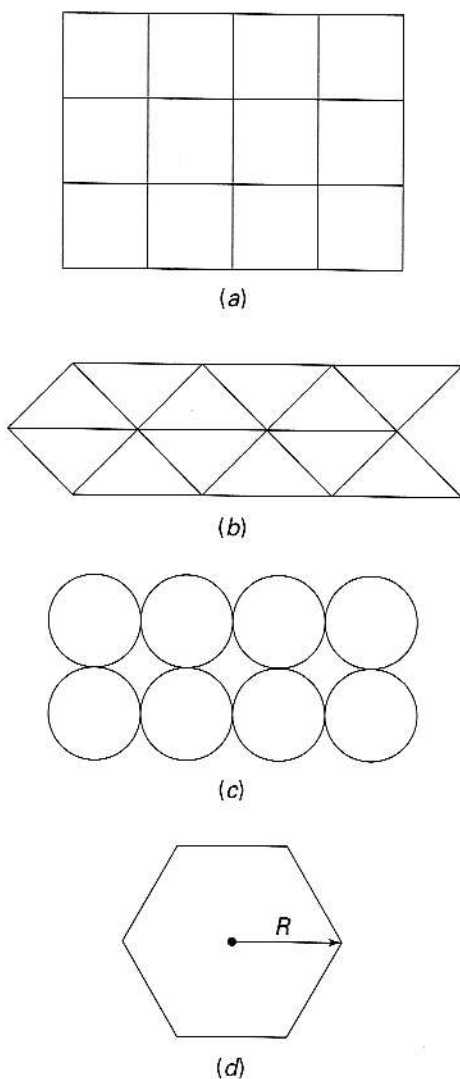

FIGURE 4.3 Different geometrical shapes for cells. (a) Square. (b) Triangular. (c) Circular. (d) Hexagonal, where R is the "radius" of the hexagon.

4.1 GEOMETRY OF A HEXAGONAL CELL

A geographical region filled with hexagonal cells is shown in Figure 4.4. Note that the xy -axes do not match the uv -axes of the hexagonal system. The distance, R , from the center of a cell to its vertex is defined as the cell radius. The center-to-center distance between two neighboring cells is therefore $2R \cos(\pi/6)$, or $\sqrt{3}R$. The center-to-center distance, D , between two cells with coordinates (u_1, v_1) and (u_2, v_2) is

$$D = \{(u_2 - u_1)^2 \cos^2(\pi/6) + [(v_2 - v_1) + (u_2 - u_1) \sin(\pi/6)]^2\}^{1/2}. \quad (4.1)$$

This equation can be simplified to

$$D = \sqrt{(u_2 - u_1)^2 + (v_2 - v_1)^2 + (u_2 - u_1)(v_2 - v_1)}. \quad (4.2)$$

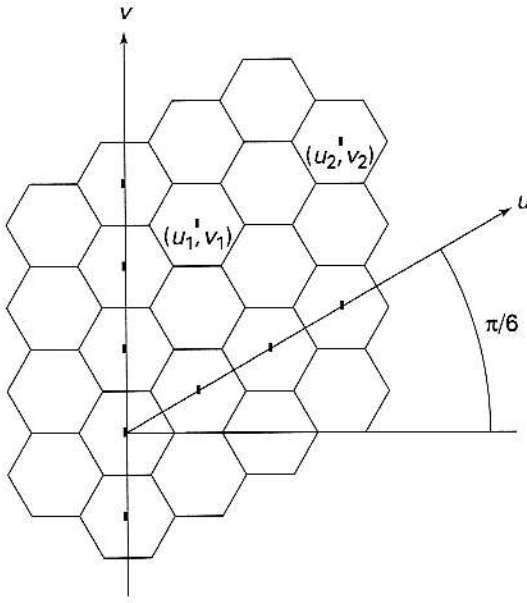

FIGURE 4.4 The concept of a hexagonal cell. The coordinates of the center of a cell are (u, v) . The hexagonal coordinates (u, v) do not match the rectangular coordinates (x, y) .

In writing eq. (4.2), we have not made use of the information that the radius of the cell is R . Incorporating this information, and assuming that the first cell is centered at the origin ($u = 0, v = 0$), the equation for the distance between any two cells can be expressed as

$$D = \sqrt{i^2 + j^2 + ij\sqrt{3}} R, \quad (4.3)$$

where (i, j) represents the center of a cell in the (u, v) coordinate system. For adjoining cells, either i or j can change by 1, but not both. Therefore, the distance between nearby cells is $\sqrt{3} R$. Since i and j can take only integer values, it is possible to define the number of cells, N_c , that lie within an area of radius D as

$$N_c = D_R^2, \quad (4.4a)$$

where

$$D_R = \sqrt{i^2 + j^2 + ij}. \quad (4.4b)$$

The quantity D_R is the normalized separation between any two cells and depends only on the cell number as counted from the cell at the origin, or the reference cell (Lee 1986, 1991b). The number of cells can thus take values of only 1, 3, 4, 7, 9, 12, 13, etc. Figure 4.5 shows a seven-cell ($N_c = 7$) cluster, and the shaded cells are

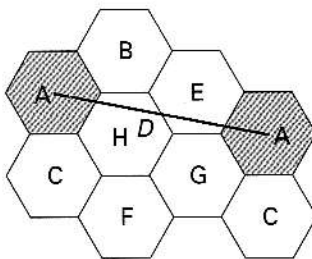

FIGURE 4.5 Frequency reuse pattern of cells. The letters (except D) represent the different channels. D is the distance between cells using the same frequency.

TABLE 4.1 Relationship between i, j , and the Number of Cells in a Cluster

i	j	N_c	$q = D/R$
1	0	1	1.73
1	1	3	3
2	0	4	3.46
2	1	7	4.58
3	0	9	5.2
2	2	12	6

co-channel cells that use the same channel (frequency band A). Table 4.1 shows the relationship between i, j , and the number of cells in a cluster.

4.2 CO-CHANNEL INTERFERENCE (CCI)

If the cell sizes are fixed, the interference from another channel using the same frequency will be determined by the location of the interfering cell from the primary cell. A typical reuse of channels is shown in Figure 4.6. Corresponding letters represent identical channels, and it can be seen that the frequencies can be used and reused over and over again in cells separated by a certain distance. The frequency reuse (Naga 1987; Lee 1986, 1991b, 1993, 1997) is therefore determined by the signal-to-noise (S/N) ratio, or, more specifically, the signal-to-CCI ratio (S/I). The signal-to-noise ratio is given by

$$\frac{S}{N} = \frac{\text{signal power}(S)}{\text{noise power}(N_s) + \text{interfering signal power}(I)}, \quad (4.5)$$

and the signal-to-CCI ratio is given by

$$\frac{S}{I} = \frac{\text{signal power}(S)}{\text{interfering signal power}(I)}.$$

If the noise at the receiver (N_s) is negligible, the signal-to-noise ratio and signal-to-CCI ratio will be equal,

$$\frac{S}{N} = \frac{S}{I}. \quad (4.6)$$

The signal power is proportional to $R^{-\nu}$ while the CCI power is proportional to $D^{-\nu}$, where ν is the loss exponent or loss factor, described in Chapter 2. If we assume that all interfering cells are at the same distance, the signal-to-CCI ratio can be expressed as

$$\frac{S}{I} = \frac{R^{-\nu}}{\sum_{k=1}^{N_I} D_k^{-\nu}} = \frac{R^{-\nu}}{N_I D^{-\nu}}, \quad (4.7)$$

where the number of interfering cells is N_I . For a seven-cell cluster $N_I = 6$. D_k is the distance of the k th interfering cell and is equal to D in the ideal case where all interfering cells are at the same distance. Using eqs. (4.4) and (4.7), S/I becomes

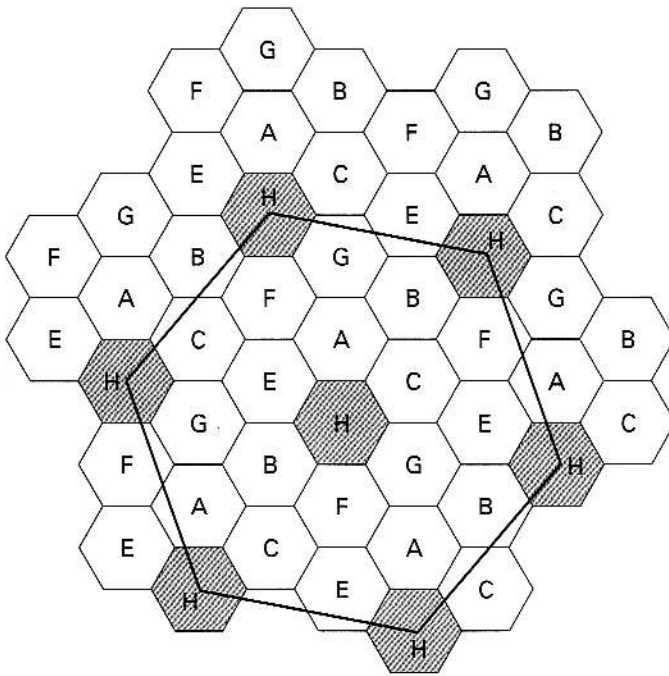

FIGURE 4.6 Expanded view of the cell structure showing a seven-cell reuse pattern.

$$\frac{S}{I} = \frac{1}{6} \left(\frac{D}{R} \right)^{\nu} = \frac{1}{6} (3N_c)^{\nu/2} \quad (4.8)$$

For a seven-cell cluster, there are six interfering cells and the signal-to-CCI ratio is $(1/6)(21)^{\nu/2}$. For $\nu = 4$, this corresponds to 73.1, or about 18.6 dB. The quantity D/R is a measure of the interference since the farther away the interfering cell is, the smaller the interfering signal power. Because of this, $q = D/R$ is also known as the *frequency reuse factor* or *co-channel interference reduction factor*. Table 4.2 gives values for q along with S/I for the ideal case of equidistant interfering cells.

TABLE 4.2 Relationship between i, j , and S/I

i	j	N	q	S/I (dB)
1	1	3	3.0	16.1
1	2	7	4.6	18.7
2	0	4	3.5	16.8
2	1	7	4.6	18.7
2	2	12	6.0	20.7
3	0	9	5.2	19.6
3	1	13	6.2	21.0
3	2	19	7.5	22.6
3	3	27	9.0	24.0
4	0	16	6.9	21.9
4	1	21	7.9	23.0
4	2	28	9.2	24.2
4	3	37	10.5	25.3

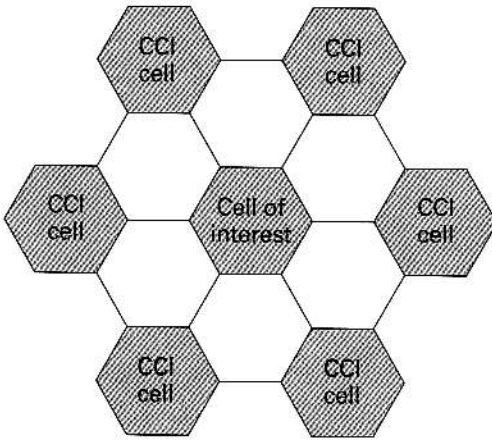

FIGURE 4.7 A three-cell pattern showing six interfering cells ($D = \sqrt{3N_c} = 3$).

A three-cell reuse pattern is shown in Figure 4.7. Comparison of Figures 4.6 and 4.7 clearly shows that irrespective of the number of cells in a cluster, the number of interfering cells is 6.

4.2.1 Special Cases of Co-Channel Interference

It is possible that the mobile unit operating at the edge of a cell will experience a high level of co-channel interference. In this case, the MU unit is receiving the weakest possible signal from its own base station while it is likely to receive stronger interfering signals from the co-channels, as shown in Figure 4.8.

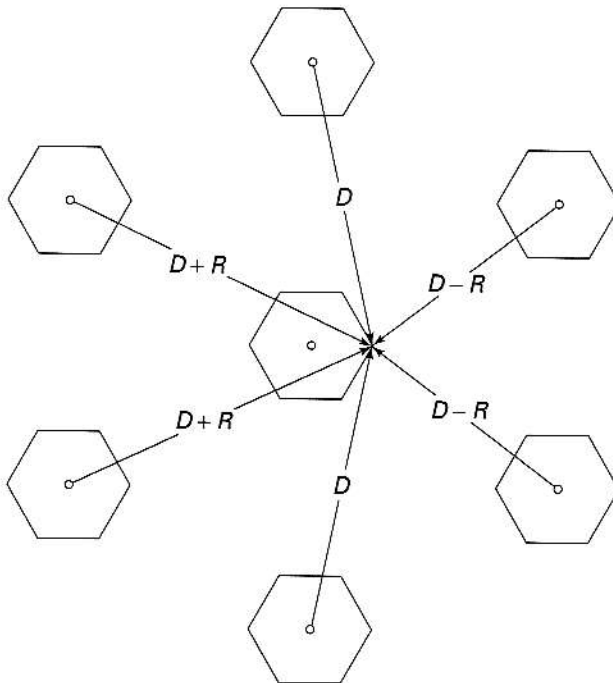

FIGURE 4.8 Geometry for the calculation of co-channel interference.

Based on the geometry shown in Figure 4.8, the signal-to-CCI ratio for a seven-cell reuse pattern can be expressed as (Lee 1986, Garg 1996, Oett 1983, Hamm 1998)

$$\frac{S}{I} = \frac{R^{-\nu}}{2(D-R)^{-\nu} + 2D^{-\nu} + 2(D+R)^{-\nu}} \quad (4.9)$$

Noting that $q = D/R$ for a seven-cell reuse pattern is equal to 4.6, S/I can be found to be equal to 54.3, or about 17 dB. However, if we use the shortest distance for all the interferers, S/I becomes

$$\frac{S}{I} = \frac{R^{-\nu}}{6(D-R)^{-\nu}} = \frac{1}{6(q-1)^{-\nu}} \quad (4.10)$$

and will be equal to only about 14 dB. If the acceptable S/I is set at a value of 18 dB, co-channel interference can make the system performance unacceptable. Of course, it is possible to increase S/I by using a cluster of 12 or more cells. But this improvement in performance will be gained at the expense of reduced capacity, since the number of users in a given geographical area will be reduced by increasing the frequency reuse factor. Before we examine ways of maintaining an acceptable S/I , we will consider the case of a single interferer, since this case is more likely to occur than the one where all six interfering cells are active.

EXAMPLE 4.1

In a cellular system, the received power at the mobile unit is -98 dBm. The cell structure is a seven-cell reuse pattern. If the thermal noise power is -120 dBm and the CCI from each interfering station is -121 dBm, calculate the signal-to-CCI ratio and signal-to-noise ratio.

Answer Converting from dBm to mW, we get signal power $P_s = 10^{-9.8}$ mW, noise power = 10^{-12} mW, CCI power = $10^{-12.1}$ mW. Signal-to-CCI ratio = $10^{-9.8}/(6 \times 10^{-12.1}) = 33.254$ or $10 \log_{10}(33.254)$ dB = 15.22 dB. Signal-to-noise ratio = $10^{-9.8}/(6 \times 10^{-12.1} + 10^{-12}) = 27.48$ or $10 \log_{10}(27.48)$ dB = 14.39 dB. ■

Special Case of a Single Interfering Cell In many practical conditions, there is a possibility that there is only one interfering cell, as shown in Figure 4.9. Depending on the location of the MU with respect to the interferer, S/I can be very low. The two cases illustrated in Figure 4.9 show the best and worst cases. S/I in this case is given by

$$\frac{S}{I} = \frac{R^{-\nu}}{D^{-\nu}} \quad (4.11)$$

The S/I values will vary depending on the distance D .

EXAMPLE 4.2

Consider a mobile unit operating at a distance of 6 km from its own base station. A single interfering station is operating at a distance of 15 km from the mobile unit. If the loss factor ν is 3.5, calculate the signal-to-CCI ratio.

Answer Signal power $\propto 6^{-\nu}$; CCI $\propto 15^{-\nu}$. Signal-to-CCI ratio = $(15/6)^{\nu} = (15/6)^{3.5} = 24.7$, or $10 \log_{10}(24.7)$ dB = 13.92 dB. ■

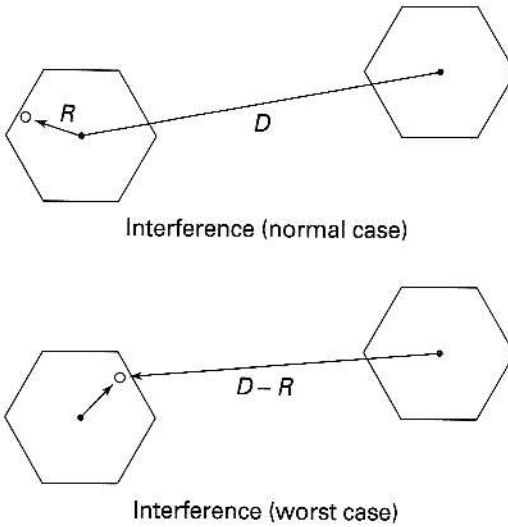

FIGURE 4.9 Special cases of a single interfering cell.

4.3 CCI REDUCTION TECHNIQUES

One of the ways in which CCI can be reduced is through the use of a 12-cell reuse pattern. This may be unacceptable because it reduces the number of users in a given geographical area serviced by a provider. On the other hand, if it is possible to replace the omnidirectional antenna with a directional antenna, some of the interfering signals will never reach the primary mobile unit, thus reducing CCI and improving the signal-to-CCI ratio (Rapp 1996b, Samp 1997, Lee 1986, Wese 1998). This can be accomplished through the use of a 120° sector antenna or a 60° sector antenna.

4.3.1 Directional Antenna Using Three Sectors

In Figure 4.10 each cell is divided into three sectors, with each sector having its own set of frequencies. For a seven-cell cluster, the primary MU will receive interfering signals from only two other cells (instead of six, as with an omnidirectional antenna)

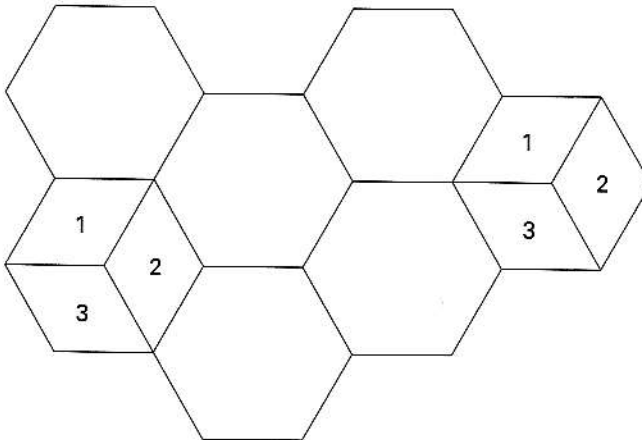

FIGURE 4.10 Concept of a three-sector antenna.

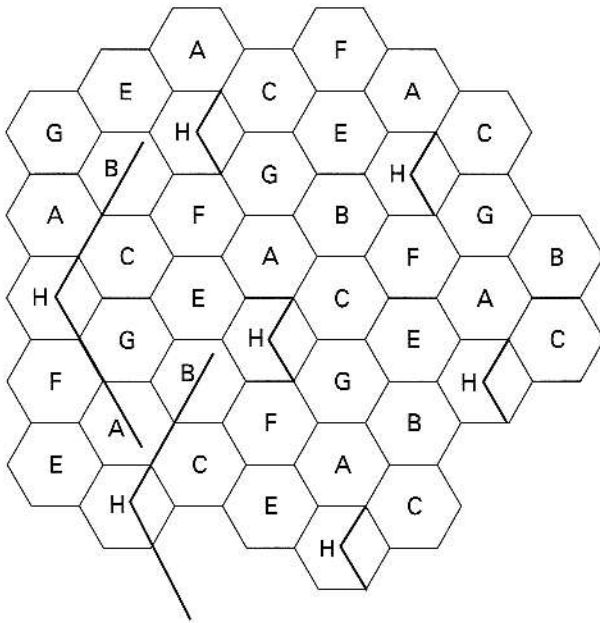

FIGURE 4.11 The interfering cells can be identified by following the radiation pattern of the sector antennae.

because of the directional pattern of the antenna, as seen in Figure 4.11. The S/I ratio can now be expressed in the worst-case scenario (when the MU is at the edge of its own cell as shown in Figure 4.9) as follows:

$$\frac{S}{I} = \frac{R^{-\nu}}{D^{-\nu} + (D + .7R)^{-\nu}} \quad (4.12)$$

In the best-case scenario, the two interferers will be at a distance of D , and the signal-to-CCI ratio for a 120° sector antenna can now be obtained from the corresponding ratio for the omnidirectional antenna by noting that the omni antenna has six interferers:

$$\left[\frac{S}{I} \right]_{120^\circ} = \left[\frac{S}{I} \right]_{\text{omni}} + 10 \log 3 = \left[\frac{S}{I} \right]_{\text{omni}} + 4.77 \text{ dB} = 23.4 \text{ dB} \quad (4.13)$$

Thus, compared with the performance of an omni antenna, a 120° sector antenna provides a signal-to-CCI ratio improvement of 4.77 dB.

4.3.2 Directional Antenna Using Six Sectors

In Figure 4.12 each cell is divided into six sectors and it can be seen that there will be only a single interferer, reducing the CCI and improving the S/I ratio. The improvement in S/I using a 60° sector antenna can be obtained once again by noting that there is only a single interferer, compared with six interferers for an omnidirectional antenna, as shown in Figure 4.13.

$$\left[\frac{S}{I} \right]_{60^\circ} = \left[\frac{S}{I} \right]_{\text{omni}} + 10 \log 6 = \left[\frac{S}{I} \right]_{\text{omni}} + 7.78 \text{ dB} = 26.4 \text{ dB} \quad (4.14)$$

indicating a 7.78 dB improvement in the performance of a 60° sector antenna system.

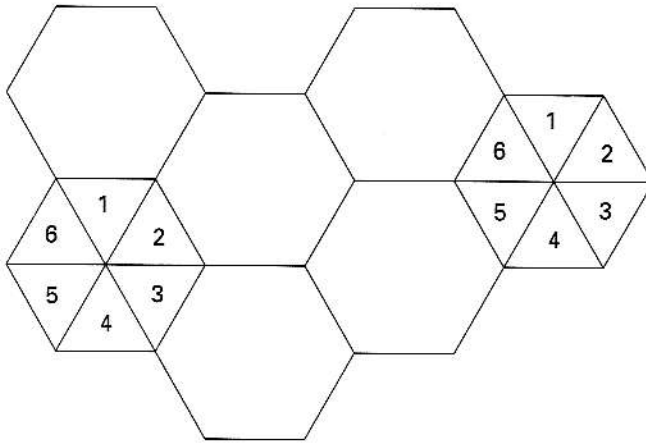

FIGURE 4.12 A 60° sector antenna arrangement.

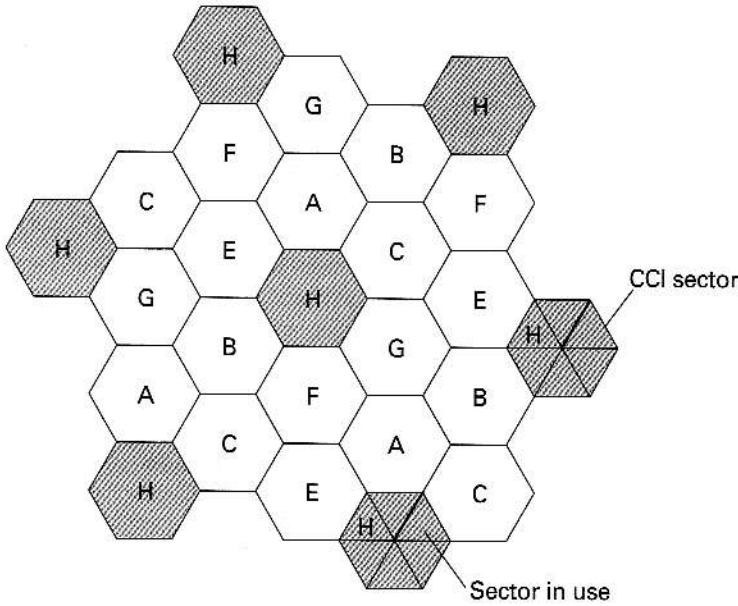

FIGURE 4.13 Interfering element in a six-element antenna scheme.

A Comment on the Use of Sector Antennae There is a major drawback to the sectorized antenna approach to improving the S/I ratio. Sectorized antennae adversely affect the overall capacity of the system (Chan 1992). This can be explained using the concept of *trunking*. We will look at this drawback after we have presented the trunking concepts in Section 4.7.

4.3.3 Geographical Model with Several Tiers of Interferers

The previous sections dealt with the case of a single tier of channel interference at a distance of D . However, as shown in Figure 4.14, other tiers can produce additional interference terms. The first tier is at a distance of D and the second tier is at a

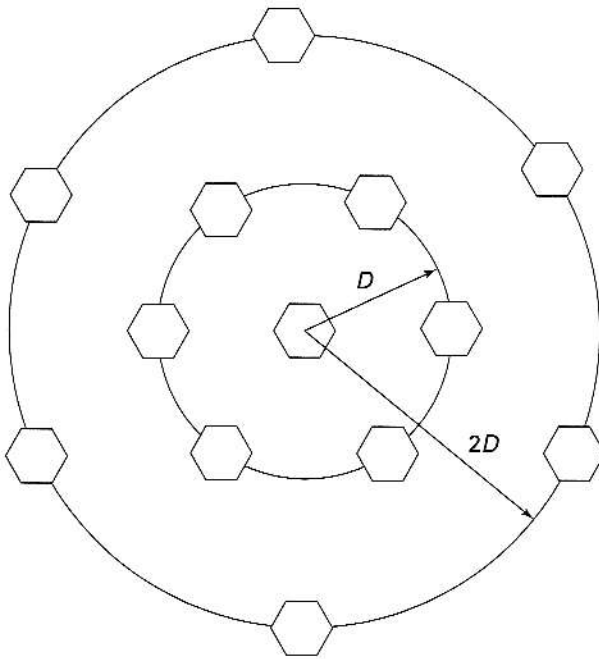

FIGURE 4.14 Geographical model with multiple interferers.

distance of $2D$. In general, tiers exist at distances of kD , $k = 1, 2, \dots$. The signal-to-CCI ratio in this case can be expressed as

$$\frac{S}{I} = \frac{R^{-\nu}}{6D^{-\nu} + 6(2D)^{-\nu} + 6(3D)^{-\nu}}, \quad (4.15)$$

where the second term in the denominator comes from the six interferers in the second tier, and the third term comes from the six interferers from the third tier. In most cases, these interference terms from the second and third tiers are negligible (Lee 1986, Hamm 1998).

4.4 CELL SPLITTING

One of the ways in which capacity can be increased is through the technique known as cell splitting. In this case, a congested cell is divided into smaller cells. Each smaller cell, a minicell, will have its own transmitting and receiving antennae. Cell splitting thus allows the frequencies/channels to be reused, since the size of the cell has been reduced for a given geographical region.

If each cell size is reduced by half, as shown in Figure 4.15 (where the smaller cells are shown in boldface), the power requirements change (Cox 1982, Lee 1991b, Rapp 1996b). This is necessary to maintain an acceptable signal-to-CCI ratio. It is possible to calculate the reduction in power. If the power required at the cell boundary in an unsplit cell is P_u , we can write this expression as

$$P_u = P_{tu}R^{-\nu}, \quad (4.16)$$

where P_{tu} is the transmitted power. The power received at the new, smaller cell boundary, P_{su} , is

$$P_{su} = P_{st}(R/2)^{-\nu}, \quad (4.17)$$

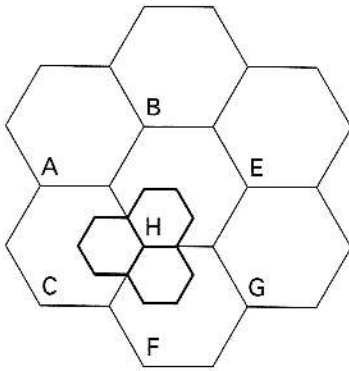

FIGURE 4.15 Cell splitting. The dark borders indicate newly created cells.

where P_{st} is the transmitted power from the antenna of the new cell. To maintain the same CCI performance, P_u must equal P_{su} , and this means that the transmitted power in the smaller cell, P_{st} , is given by

$$P_{st} = \frac{P_{tu}}{16} \quad (4.18)$$

for the case of $\nu = 4$. In other words, the new transmitted power is reduced by about 12 dB.

Note that all cells may not be split. Cell splitting can be accomplished on an as-needed basis. If it is possible to know when there is a likelihood of increased traffic in certain cells, careful planning can be done beforehand to convert some of the cells to minicells or break them down further to microcells.

EXAMPLE 4.3

The transmit power of a base station is 5 W. If the coverage of this region is to be split in half so that minicells (of half the size) can be created to accommodate additional users in the region, what must be the transmit power of the base station (of this minicell) to keep CCI at the same level as that of the unsplit cell? Assume that $\nu = 3.2$.

Answer To keep the CCI from the interfering stations unchanged, we need to keep the power at the boundary the same, regardless of whether the cell has been split or not. If R is the diameter of the unsplit cell, we must have $5R^{-\nu} = P(R/2)^{-\nu}$, where the left-hand side is the power at the boundary of the unsplit cell and the right-hand side is the power at the boundary of the new cell (half the size). P is the transmit power of the BS of the newly created minicell, $P = 5/(2)^\nu = 5/9.186 = 544 \text{ mW}$. ■

4.5 MICROCELLS, PICOCELLS, AND FIBEROPTIC MOBILE SYSTEMS

One of the drawbacks of cell splitting is the complexity of the multiple hand-offs necessary over small distances. As we decrease the coverage area by going from a macrocell to a minicell, and then to a microcell and a picocell, the complexity of the operation over a given geographical area increases significantly (Lee 1997, Rapp 1996b, Yeun 1996). The number of hand-offs performed by the base station goes up since the geographical region covered becomes split into an increasing number of

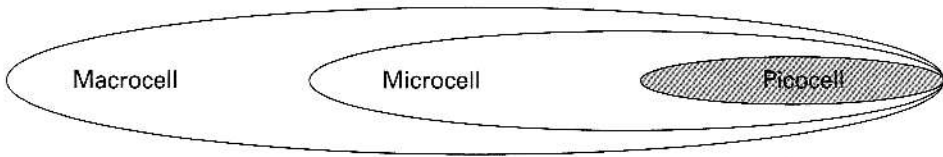

FIGURE 4.16 The areas corresponding to a macrocell, microcell, and picocell.

smaller and smaller cells, as shown in Figure 4.16. Along with this comes the additional workload of switching and control elements of the mobile system. This problem can be solved using a fiberoptic mobile (FOM) system (Chu 1991, Kaji 1996, Shib 1993, Way 1993). In this arrangement, several base stations are linked using optical fibers and are thereby controlled from a single location. The schematic in Figure 4.17 shows this principle (Kosh 1997). The base stations merely act as transmitter/receiver stations, and most of the switching and channel allocation functions are centrally undertaken. The same concept can be applied to systems that employ sector antennae.

The electrooptic (E/O) and optoelectronic (O/E) elements provide the conversion from the electrical to optical and optical to electrical signals, respectively. The low-noise amplifiers (LNA) and high-power amplifiers (HPA) provide the amplification needed. Note that this system is not without problems, most of which arise from the nonlinear behavior of the laser diodes used at the modulator stage.

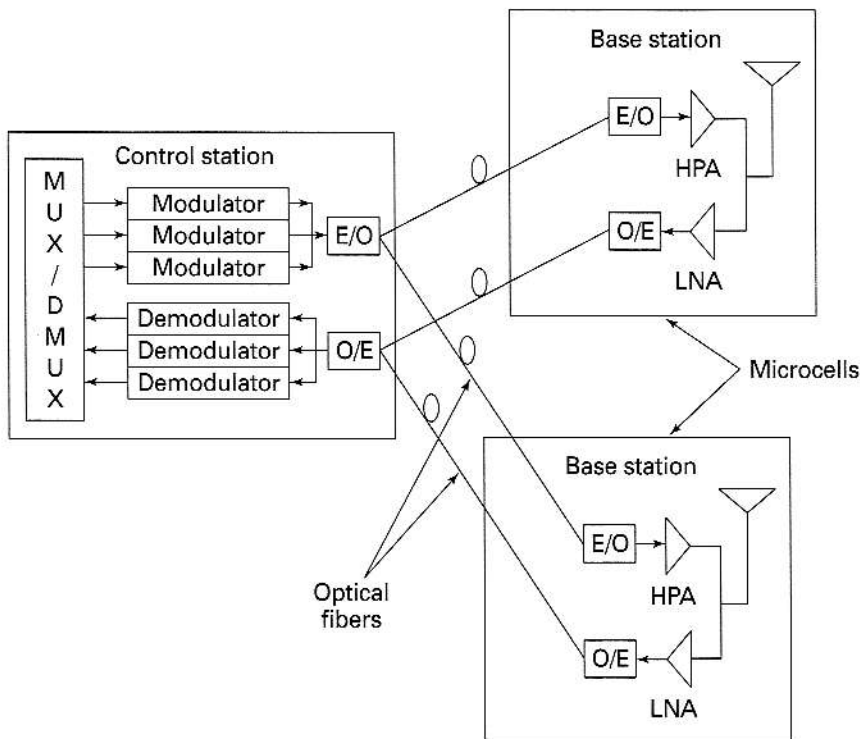

FIGURE 4.17 The concept of a fiberoptic mobile system.

4.6 COVERAGE AREA ESTIMATION

We have examined the concept of a cell and the origins of CCI. We still need to understand how to arrive at the maximum radius, R , of the cell. To estimate the coverage area, we must consider the following:

Transmitter power, P_T (dBm)

Sensitivity of the receiver, or the threshold power, P_{th} (dBm)

Power loss from transmission, L_p (dB)

Under ideal conditions, it is possible to estimate the maximum distance between the transmitter and receiver from the following:

$$L_p = P_T - P_{th}. \quad (4.19)$$

The distance can then be estimated from eq. (2.9) or directly from the Hata model, eq. (2.10). However, this simplistic approach ignores the fact that the signal undergoes long-term fading, which could reduce the received power at any given location by 10 dB in urban areas and a few decibels in rural areas. Since the fading is long term, no improvements can be expected if the MU moves through a short distance. It is therefore necessary to compensate for a fading margin, M , to account for the lognormal fading (Jake 1974, Pale 1991, Pars 1992, Samp 1997, Akai 1998) seen. Equation (4.19) needs to be rewritten as

$$L_p = P_T - P_{th} - M, \quad (4.20)$$

thereby reducing the permitted loss in the transmission and, consequently, reducing the transmission distance. We will now examine ways to calculate the fading margin, M .

Computation of the Fading Margin The probability density function of the received power under long-term fading conditions is given by eq. (2.67), reproduced here:

$$f(p_{LT}) = \frac{1}{\sqrt{2\pi\sigma^2 p_{LT}^2}} \exp\left[-\frac{1}{2\sigma^2} \ln^2\left(\frac{p_{LT}}{p_0}\right)\right], \quad (4.21)$$

where p_{LT} is the power in milliwatts. Whenever the received power falls below the minimum required power, P_{th} , the system goes into outage (Hata 1985, Coul 1998, Pahl 1995). The outage probability, P_{out} , can be defined as the probability that the received signal power fails to reach the threshold (Jake 1974, Hata 1985). If R is the maximum radius of the cell, the outage probability at the boundary, $P_{out}(R)$, can be expressed as

$$P_{out}(R) = \int_0^{P_{th}} f(p_{LT}) dp_{LT}. \quad (4.22)$$

Using eq. (4.21), the outage probability given in eq. (4.22) becomes

$$P_{out}(R) = \frac{1}{2} \operatorname{erfc}\left[\frac{\ln(P_0(R)/P_{th})}{\sqrt{2}\sigma}\right]. \quad (4.23)$$

The quantity $P_0(R)$ is the median power at the distance R calculated from the Hata model. When the terminal is at a distance r from the transmitter, the received power, $P_0(r)$, can be expressed as

$$P_0(r) = P_0(R) \left[\frac{R}{r} \right]^\nu, \quad (4.24)$$

where ν is the loss parameter. The outage probability, $P_{\text{out}}(r)$, at a distance r can now be expressed as

$$P_{\text{out}}(r) = \frac{1}{2} \operatorname{erfc} \left\{ \frac{\ln \left[\left(\frac{P_0(R)}{P_{\text{th}}} \right) \left(\frac{R}{r} \right)^\nu \right]}{\sqrt{2} \sigma} \right\}. \quad (4.25)$$

The area outage probability, $P_{\text{aout}}(R)$, is given by the integral

$$P_{\text{aout}}(R) = \frac{1}{\pi R^2} \int_0^R P_{\text{out}}(r) 2\pi r dr. \quad (4.26)$$

The integral can be evaluated to

$$P_{\text{aout}}(R) = \frac{1}{2} \operatorname{erfc}(Q_1) - \frac{1}{2} e^{(2Q_1 Q_2 + Q_2^2)} \operatorname{erfc}(Q_1 + Q_2), \quad (4.27)$$

where Q_1 and Q_2 are given by

$$Q_1 = \frac{\ln \left[\frac{P_0(R)}{P_{\text{th}}} \right]}{\sqrt{2} \sigma}, \quad Q_2 = \frac{\sqrt{2} \sigma}{\nu}. \quad (4.28)$$

The fading margin, M (dB), is given by

$$M = 10 [\log_{10} P_0(R) - \log_{10} P_{\text{th}}] \text{ dB}. \quad (4.29)$$

Redefining the fading margin in terms of a scaling factor, m ,

$$M = 10 \log_{10} \left[\frac{P_0(R)}{P_{\text{th}}} \right] = 10 \log_{10}(m), \quad (4.30)$$

the parameter Q_1 can be rewritten without any dependence on the threshold power as

$$Q_1 = \frac{\ln \left(10^{M/10} \right)}{\sqrt{2} \sigma}. \quad (4.31)$$

It is possible to see the effect of the fading margin (M) on the outage probability. The outage probability at the boundary of the cell, given in eq. (4.23), is shown in

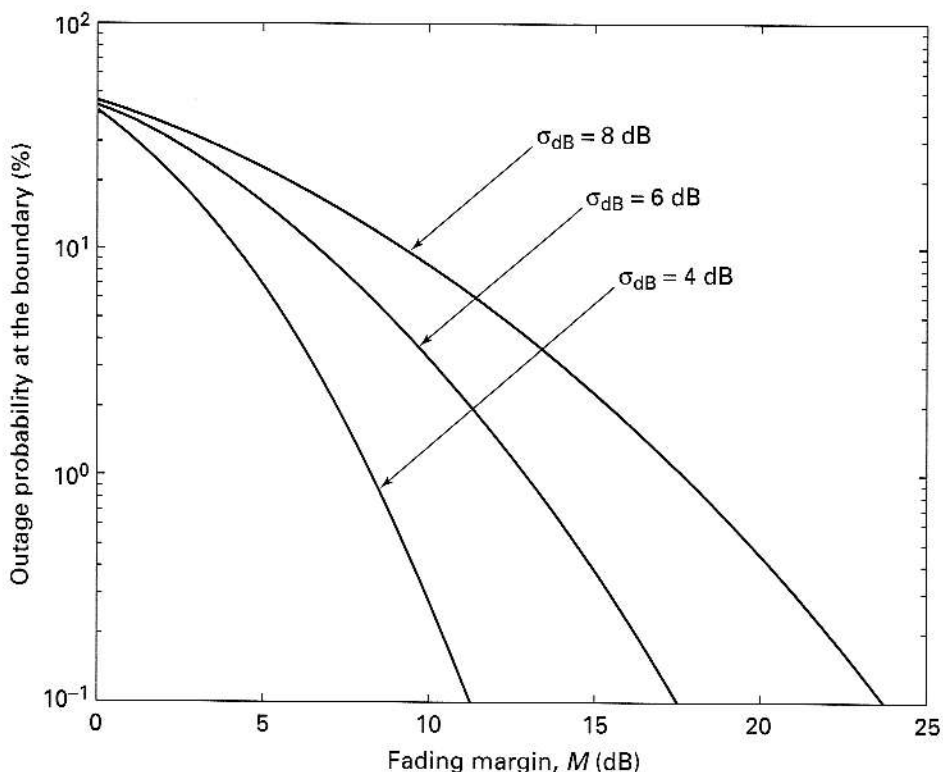

FIGURE 4.18 The outage probability (%) at the boundary of the cell is plotted as a function of fading margin M (dB). The relationship between σ and the standard deviation of fading, σ_{dB} , is given in eq. (2.68).

Figure 4.18. As expected, the outage probability goes up as the standard deviation of lognormal fading goes up, and the power margin required to maintain a fixed outage probability goes up as the fading level (given by σ) increases. Note that there is no explicit dependence on the loss parameter ν .

The area outage probability, given in eq. (4.27), is shown in Figure 4.19. Comparing Figures 4.18 and 4.19 (as well as the two equations for the outage probabilities), the outage probability at the boundary provides us with the worst-case scenario and can therefore be used to calculate the maximum coverage. It is worth mentioning that the area outage probability also depends on the loss parameter ν .

Link Budget Link budget calculations are performed to estimate the maximum coverage that can be obtained. These calculations are based on the minimum power required to maintain acceptable performance, transmitted power, and the power margin needed to mitigate fading. Note that, in general, two margins have to be applied: a power margin, M_1 , to account for long-term fading (lognormal) and a second margin, M_2 , to account for the short-term fading. This concept is illustrated in Figure 4.20. The distance d_0 is the maximum coverage based on pure attenuation, and with the incorporation of the long-term fading margin, the coverage drops to d_1 . If we include the short-term fading margin, the coverage drops to d_2 . The schematic in Figure 4.20 reflects the relationship between attenuation, long-term fading, and short-term fading illustrated in Figure 2.5.

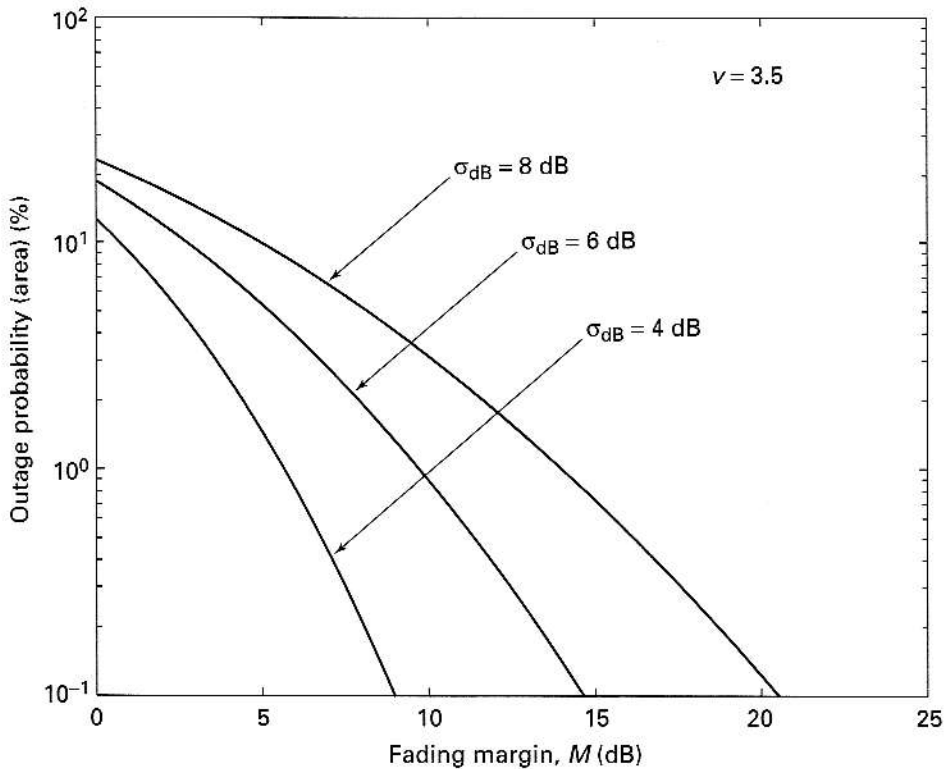

FIGURE 4.19 The area outage probability (%) is plotted as a function of fading margin M (dB). The relationship between σ and the standard deviation of fading σ_{dB} is given in eq. (2.68).

EXAMPLE 4.4

To keep an acceptable level of performance, a service provider is planning to maintain an outage probability of 2%. What is the power margin needed to achieve this goal (assume the worst-case scenario) when the standard deviation of fading has been found to be 5 dB?

Answer The outage probability is given by eq. (4.23), which can be rewritten as

$$P_{\text{out}}(R) = 0.5 \operatorname{erfc}\left(\frac{m}{\sigma\sqrt{2}}\right)$$

and the power margin in dB is given by

$$M = 10 \log_{10}(m).$$

The relationship between σ and σ_{dB} is given in eq. (2.68) as

$$\sigma = \left(\frac{1}{10}\right) \ln(10) \sigma_{\text{dB}}.$$

We therefore have $\sigma = 1.15$. Thus

$$\text{Outage probability} = 0.02 = 0.5 \operatorname{erfc}\left(\frac{m}{1.6282}\right).$$

As we did in Chapter 3, we can solve this using the MATLAB function *erfcinv*. We get $m = 2.36$ and $M = 3.73$ dB. ■

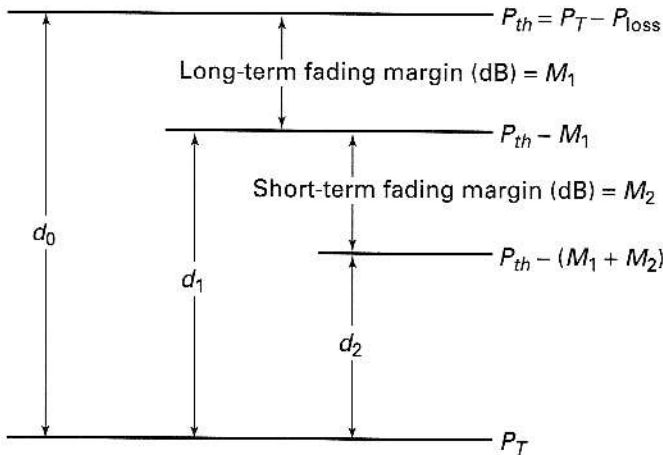

FIGURE 4.20 The margins for fading and the consequent reduction in coverage.

EXAMPLE 4.5

In a cell, the received power measured at a distance of 6 km from the BS is -65 dBm. The threshold level for acceptable performance is -90 dBm. If the power margin is the value obtained from Example 4.4, what is the distance that can be covered? Assume that the path loss exponent is 3.2.

Answer We have been given the power at 6 km = -65 dBm or $10^{-6.5}$ mW. Margin = 4.3 dB. Minimum required power = $-90 + 4.3 = -85.7$ dBm or $10^{-8.57}$ mW. Making use of the path loss, we have

$$10^{-6.5} \propto \left(\frac{1}{6}\right)^{3.2}$$

and

$$10^{-8.57} \propto \left(\frac{1}{d}\right)^{3.2},$$

where d is the maximum distance for acceptable performance. Solving, we get $d = 25$ km. ■

4.7 TRAFFIC CAPACITY AND TRUNKING

A question commonly asked is, How can we compare the quality of service provided by the various cellular providers? What is the probability of *not* being able to make a call when you want to make one? What is the probability that you will have to wait before getting connected? To answer some of these questions, we need to understand the concepts of telephone trunking and “grade of service” (GOS). Typically there are more users than the number of channels or trunks available. Telephone trunking allows the provider to use a limited bandwidth to accommodate a large number of users. It relies on the principle that not everybody will be using the telephone line at the same time. Thus, each user gets access to a channel as and when the user needs it. When the call is completed and terminated, the channel is freed and made available to other users. There is, of course, a problem. If everybody in the system wishes to make use of their cell phones at the same time, only a limited number of users will be allowed to get connected. This leads to a user being denied access, or being blocked.

“Grade of service” is a measure of the blocking that may take place, or the ability of the user to gain access to the system during the busiest hour.

GOS is determined by the available number of channels and is used to estimate the number of total users that can be supported by the network. To understand the concept of GOS, we first need to define traffic intensity. The unit of traffic intensity is the Erlang (Hong 1986, Jake 1974). If a person is using the phone at a rate of two calls/hour and stays on the phone for an average time of 3 minutes per call, the traffic intensity generated by this user is

$$2 \times \frac{3}{60} = 0.1 \text{ Erl.} \quad (4.32)$$

In other words, this user generates one-tenth of an Erlang. The Erlang is thus a measure of the unit of traffic intensity given by the product of the number of calls/hour and the duration of the call (in hours).

The traffic intensity generated by a user, A_I , is given by

$$A_I = \lambda T_H \text{ Erl,} \quad (4.33)$$

where λ is the average number of calls/hour and T_H is the duration of the calls (in hours). If there are K users in the system supported by a certain provider, the provider must be able to sustain a traffic intensity of A_{tot} , given by

$$A_{\text{tot}} = K \times A_I \text{ Erl.} \quad (4.34)$$

The provider certainly must be able to allow the K users to access the system during the peak period, when everybody is trying to access the system, with an acceptable performance criterion or grade of service. To achieve a certain performance criterion or blocking probability, $p(B)$, the provider must be able to offer a certain number of channels or trunks in the network. This will determine the *offered traffic*. The *carried traffic* will be less than the offered traffic (Section B.2, Appendix B). The relationship between carried traffic, offered traffic, blocking probability, and number of trunks or available channels can be obtained from trunking theory.

It has been shown that the calls arriving at the network can be modeled using a Poisson process. The holding time or duration of the calls is exponentially distributed. If the number of channels or trunks available is C , the blocking probability, $p(B)$, can be expressed as

$$p(B) = \frac{\left[\frac{A^C}{C!} \right]}{\sum_{k=0}^C A^k / k!}, \quad (4.35)$$

where A is the offered traffic, given by

$$A = \frac{\Lambda}{\mu} \text{ Erl.} \quad (4.36)$$

The mean rate of call arrival is Λ , and the mean rate at which calls are terminated is μ . The mean duration of the calls is the inverse of μ . The carried traffic, A_c , can now be expressed as

$$A_c = A[1 - p(B)], \quad (4.37)$$

which takes into account the loss of calls due to blocking (Stee 1999). Equation (4.35) can be solved for various values of C and blocking probabilities to get the carried traffic. These are given in Table 4.3.

The efficiency of the channel usage, η , is given by

$$\eta = \frac{A_c}{C} = \frac{A[1 - p(B)]}{C}. \quad (4.38)$$

TABLE 4.3 Erlang B Values

Number of channels	Offered traffic			Number of channels	Offered traffic		
	$\rho=0.005$	$\rho=0.02$	$\rho=0.1$		$\rho=0.005$	$\rho=0.020$	$\rho=0.100$
1	0.005	0.020	0.111	37	24.846	28.254	35.572
2	0.105	0.224	0.595	38	25.689	29.166	36.643
3	0.349	0.602	1.271	39	26.534	30.081	37.715
4	0.701	1.092	2.045	40	27.382	30.997	38.787
5	1.132	1.657	2.881	41	28.232	31.916	39.861
6	1.622	2.276	3.758	42	29.085	32.836	40.936
7	2.158	2.935	4.666	43	29.940	33.758	42.011
8	2.730	3.627	5.597	44	30.797	34.682	43.088
9	3.333	4.345	6.546	45	31.656	35.607	44.165
10	3.961	5.084	7.511	46	32.518	36.534	45.243
11	4.610	5.842	8.487	47	33.381	37.462	46.322
12	5.279	6.615	9.474	48	34.246	38.392	47.401
13	5.964	7.402	10.470	49	35.113	39.323	48.481
14	6.663	8.200	11.474	50	35.982	40.255	49.562
15	7.376	9.010	12.484	51	36.852	41.189	50.644
16	8.100	9.828	13.500	52	37.725	42.124	51.726
17	8.834	10.656	14.522	53	38.598	43.060	52.808
18	9.578	11.491	15.548	54	39.474	43.997	53.891
19	10.331	12.333	16.579	55	40.351	44.936	54.975
20	11.092	13.182	17.613	56	41.229	45.875	56.059
21	11.860	14.036	18.651	57	42.109	46.816	57.144
22	12.635	14.896	19.693	58	42.990	47.758	58.229
23	13.416	15.761	20.737	59	43.873	48.700	59.315
24	14.204	16.631	21.784	60	44.757	49.644	60.401
25	14.997	17.505	22.833	61	45.642	50.589	61.488
26	15.795	18.383	23.885	62	46.528	51.534	62.575
27	16.598	19.265	24.939	63	47.416	52.481	63.663
28	17.406	20.150	25.995	64	48.305	53.428	64.750
29	18.218	21.039	27.053	65	49.195	54.376	65.839
30	19.034	21.932	28.113	66	50.086	55.325	66.927
31	19.854	22.827	29.174	67	50.978	56.275	68.016
32	20.678	23.725	30.237	68	51.872	57.226	69.106
33	21.505	24.626	31.301	69	52.766	58.177	70.196
34	22.336	25.529	32.367	70	53.662	59.129	71.286
35	23.169	26.435	33.434	71	54.558	60.082	72.376
36	24.006	27.343	34.503	72	55.455	61.036	73.467

(Continued)

TABLE 4.3 Erlang B Values (Continued)

Number of channels	Offered traffic			Number of channels	Offered traffic		
	$\rho=0.005$	$\rho=0.02$	$\rho=0.1$		$\rho=0.005$	$\rho=0.020$	$\rho=0.100$
73	56.354	61.990	74.558	117	96.599	104.493	122.783
74	57.253	62.945	75.649	118	97.526	105.468	123.883
75	58.153	63.900	76.741	119	98.454	106.444	124.983
76	59.054	64.857	77.833	120	99.382	107.419	126.082
77	59.956	65.814	78.925	121	100.310	108.395	127.182
78	60.859	66.771	80.018	122	101.239	109.371	128.282
79	61.763	67.729	81.110	123	102.168	110.348	129.383
80	62.668	68.688	82.203	124	103.099	111.324	130.483
81	63.573	69.647	83.297	125	104.027	112.302	131.585
82	64.479	70.607	84.390	126	104.962	113.280	132.684
83	65.386	71.568	85.484	127	105.891	114.255	133.784
84	66.294	72.529	86.578	128	106.822	115.234	134.886
85	67.202	73.490	87.672	129	107.753	116.213	135.987
86	68.111	74.453	88.767	130	108.684	117.191	137.087
87	69.021	75.415	89.861	131	109.617	118.167	138.189
88	69.932	76.378	90.956	132	110.550	119.147	139.289
89	70.843	77.342	92.051	133	111.482	120.126	140.390
90	71.755	78.306	93.147	134	112.416	121.106	141.492
91	72.668	79.271	94.242	135	113.348	122.084	142.593
92	73.581	80.236	95.338	136	114.284	123.068	143.696
93	74.495	81.201	96.434	137	115.236	124.052	144.796
94	75.410	82.167	97.530	138	116.160	125.026	145.900
95	76.325	83.134	98.626	139	117.091	126.017	147.003
96	77.241	84.100	99.722	140	118.044	127.005	148.105
97	78.157	85.068	100.819	141	118.984	127.968	149.215
98	79.074	86.035	101.916	142	119.963	128.994	150.306
99	79.992	87.004	103.013	143	120.914	129.994	151.444
100	80.910	87.972	104.110	144	121.837	130.920	152.524
101	81.829	88.941	105.207	145	122.746	131.990	153.614
102	82.748	89.910	106.305	146	123.660	132.899	154.720
103	83.668	90.880	107.402	147	124.588	133.865	155.857
104	84.588	91.850	108.500	148	125.557	134.837	156.911
105	85.509	92.821	109.598	149	126.471	135.871	158.025
106	86.431	93.791	110.696	150	127.397	136.836	159.126
107	87.353	94.763	111.794	151	128.316	137.801	160.216
108	88.275	95.734	112.892	152	129.367	138.835	161.341
109	89.198	96.706	113.991	153	130.274	139.811	162.434
110	90.122	97.678	115.089	154	131.207	140.794	163.587
111	91.046	98.651	116.188	155	132.231	141.785	164.675
112	91.970	99.624	117.287	156	133.161	142.856	165.795
113	92.895	100.597	118.386	157	134.058	143.781	166.851
114	93.820	101.571	119.485	158	134.989	144.832	168.216
115	94.746	102.545	120.584	159	136.030	146.544	169.446
116	95.672	103.519	121.684	160	136.563	147.469	170.895

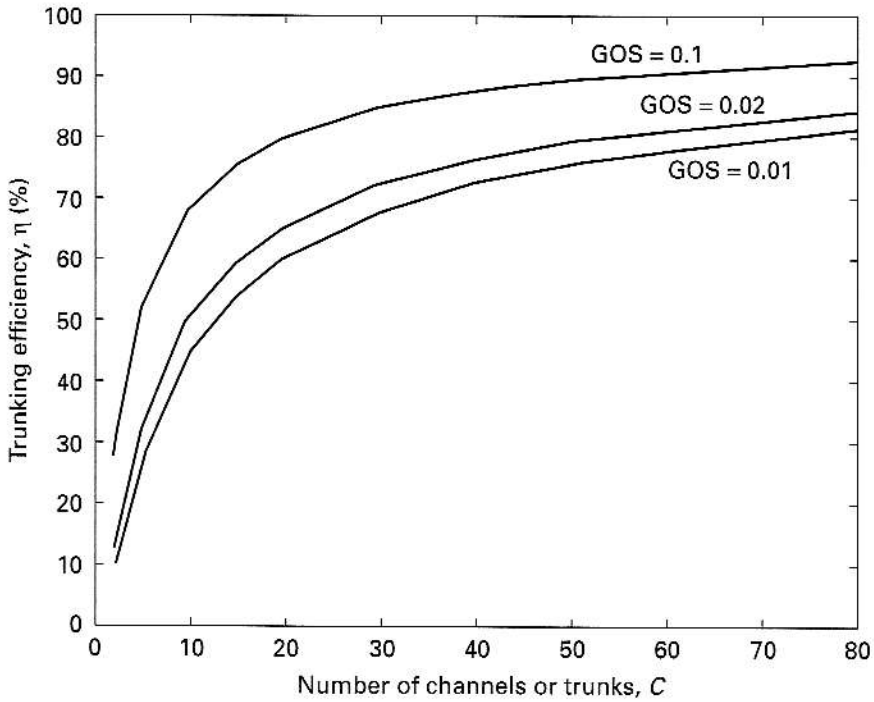

FIGURE 4.21 Trunking efficiency plots.

The efficiency increases as the number of channels, C , increases, as shown in Figure 4.21. This is known as the *trunking effect*.

Let us explore these concepts using a few examples.

EXAMPLE 4.6

If a provider has 50 channels available, how many users can be supported if each user makes an average of four calls/hour, each call lasting an average of 2 minutes? The GOS is 2%.

Answer

$$p(B) = \text{GOS} = 0.02.$$

From Table 4.3 the offered traffic with 50 available channels for a blocking probability of 0.02 is

$$A = 40.255 \text{ Erl.}$$

The carried traffic is

$$A_c = A[1 - p(B)] = 40.25 \times 0.98 = 39.445 \text{ Erl.}$$

The traffic intensity generated by each user is

$$A_I = \text{calls/hour} \times \text{call duration} = 4 \times 2/60 = 0.1333 \text{ Erl.}$$

Therefore, the maximum number of users that can be supported by this provider is

$$\frac{A_c}{A_I} = \frac{39.455}{0.1333} = 296.$$

EXAMPLE 4.7

Two service providers, I and II, are planning to provide cellular service to an urban area. Provider I has 20 cells to cover the whole area, with each cell having 40 channels, and provider II has 30 cells, each with 30 channels. How many users can be supported by the two providers if a GOS of 2% is required? Omnidirectional antennae will be used. Assume that each user makes an average of three calls/hour, each call lasting an average of 3 minutes.

Answer

Provider I:

Number of channels/cell = 40

Offered traffic at GOS of 2% = 30.99 Erl/cell

Carried traffic = $30.99 \times 0.98 = 30.4$ Erl/cell

Total traffic carried = $30.4 \times 20 = 608$ Erl

Traffic intensity/user = $3 \times 3/60 = 0.15$ Erl

Total number of users = $608/0.15 = 4054$

Provider II:

Number of channels/cell = 30

Offered traffic at GOS of 2% = 21.99 Erl/cell

Carried traffic = $21.99 \times 0.98 = 21.55$ Erl/cell

Total traffic carried = $21.55 \times 30 = 646.5$ Erl

Traffic intensity/user = $3 \times 3/60 = 0.15$ Erl

Total number of users = $646/0.15 = 4310$ ■

4.8 TRUNKING EFFICIENCY OF OMNI VERSUS SECTORIZED ANTENNAE

Now that we have reviewed the concepts of trunking, let us revisit the advantages and disadvantages of the different types of antennae used. We clearly established that the use of 120° sector antennae increases the signal-to-CCI ratio. The use of 60° antennae further increased the signal-to-CCI ratio. We did not examine the trade-off, if any, in going from an omnidirectional antenna to a sector antenna (Chan 1992). Let us compare the performance of these two structures using the traffic capacity that can be attained.

Consider a seven-cell pattern with 56 channels/sector. For an omnidirectional antenna system, this means the availability of all 56 channels in one sector. If we are using a 120° sector antenna system, we have $56/3 = 19$ channels/sector, and for a 60° sector antenna system, we have only $56/6 = 9$ channels/sector.

Omni

Number of channels = 56

Offered traffic at GOS of 2% = 45.87 Erl

Carried traffic = $45.87 \times 0.98 = 44.95$ Erl

Trunking efficiency = $44.95/56 = 80.3\%$

120° Sector

Number of channels/sector = 19

Offered traffic at GOS of 2% = 12.34 Erl/sector

Carried traffic = $12.34 \times 0.98 = 12.09$ Erl/sector

Carried traffic at this site = $12.09 \times 3 = 36.28$ Erl

Trunking efficiency = $36.28/56 = 64.8\%$

60° Sector

Number of channels/sector = 9

Offered traffic at GOS of 2% = 4.35 Erl/sector

Carried traffic = $4.35 \times 0.98 = 4.26$ Erl/sector

Carried traffic at this site = $4.26 \times 3 = 25.58$ Erl

Trunking efficiency = $25.58/56 = 45.7\%$

As we can see, the trunking efficiency of a sectorized antenna system goes down as the number of elements in the sector increases. Even though the signal-to-CCI ratio, S/I , of the antenna goes up as the number of elements goes up,

$$\frac{S}{I} = 18.7 \text{ dB} \quad (\text{omni})$$

$$\frac{S}{I} = 23.4 \text{ dB} \quad (120^\circ \text{ sector})$$

$$\frac{S}{I} = 26.4 \text{ dB} \quad (60^\circ \text{ sector})$$

the trunking efficiencies are 80.3%, 64.8%, and 45.7%, respectively.

4.9 ADJACENT CHANNEL INTERFERENCE

A discussion of cellular systems would not be complete without a mention of adjacent channel interference (ACI). ACI is caused primarily by inadequate filtering and non-linearity of the amplifiers (Fehe 1995, Samp 1998, Malm 1997, El-Sa 1996, El-Ta 1998). Inadequate filtering arises from the lack of a “brick wall” filter that keeps the spectrum in any channel limited to that channel. The effect of inadequate filtering is shown in Figure 4.22. The energy in the shaded regions corresponding to adjacent channels will cause interference. In most cases, it is sufficient to take under consideration only the interference coming from the two channels on either side of the primary channel. The shaded regions represent the energy contributions to the channel of frequency f_{c2} coming from the two nearby channels, f_{c1} and f_{c3} .

There will be signal intrusions from f_{c4} , f_{c5} , and other channels farther from the channel of interest, f_{c2} . However, the contributions from these channels decrease the farther these channels are from the channel of interest. A comparison of the ACI produced by near neighbors and far neighbors due to inadequate filtering is demonstrated in Figure 4.23.

If we compare ACI (Figure 4.23) with CCI, shown in Figure 4.24, it is clear that ACI is typically attenuated by the receiver filter, while CCI is unaffected by the

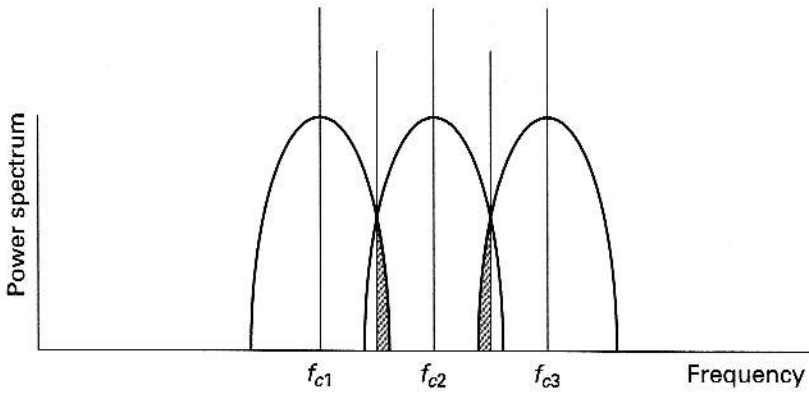

FIGURE 4.22 Adjacent channel interference (shaded regions).

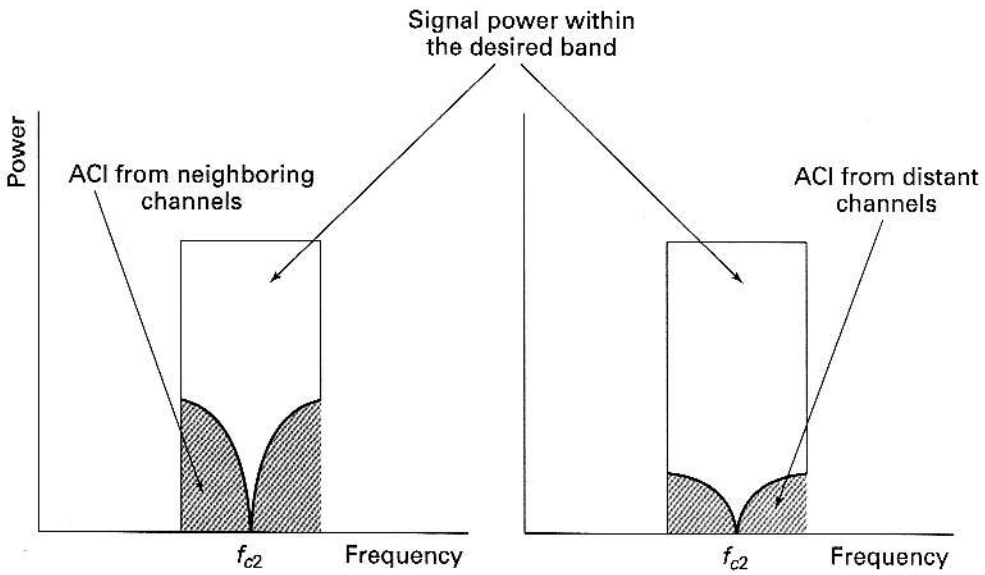

FIGURE 4.23 ACI from neighboring channels and from distant channels.

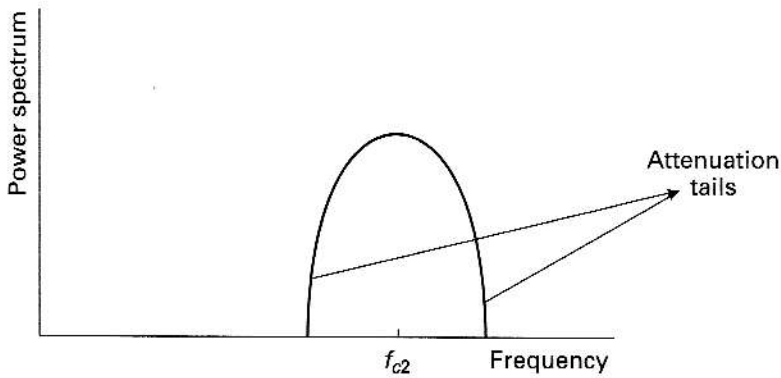

FIGURE 4.24 Characteristics of the receiving filter in the channel of interest (f_{c2}).

receiving filter attenuation characteristics since the ACI components are falling on the “tail ends” of the filter.

Based on Figure 4.23, a measure of ACI (the ACI ratio) can be expressed as (Gole 1994, Samp 1993, Malm 1997)

$$\text{ACI ratio} = \frac{\int_{-\infty}^{\infty} G(f) |H_B(f - \Delta f)|^2 df}{\int_{-\infty}^{\infty} G(f) |H_B(f)|^2 df}, \tag{4.39}$$

where $H_B(f)$ is the transfer function of the bandpass filter and Δf is the channel separation. The power spectral density of the signal is given by $G(f)$.

One of the ways ACI can be reduced is through an increase in the channel separation. It can also be reduced by an appropriate channel allocation scheme and cluster as well as selection of cell sizes. ACI is also a function of its origin; i.e., if the adjacent channel is from the group of frequencies (including the signal) assigned to one base station, the ACI undergoes the same path-dependent attenuation as the signal component, while if the ACI originates from a channel from a different base station, it undergoes a higher attenuation due to the distance compared with the signal from its base station. The latter case is illustrated in Figure 4.25, where distance $d_{\Delta f} > d_f$.

The overall performance of the cellular systems is determined by the total signal-to-interference ratio, $(S/I)_{\text{tot}}$, given by

$$\left(\frac{S}{I}\right)_{\text{tot}} = \frac{S}{\text{CCI} + \text{ACI}}. \tag{4.40}$$

It is possible to develop a strategy based on channel separation, cell size, cluster size, and antenna directivity to overcome the problems caused by CCI and ACI (Samp 1993, Malm 1997). The effects of ACI can also be reduced by using advanced signal-processing techniques that employ equalizers (Pete 1992).

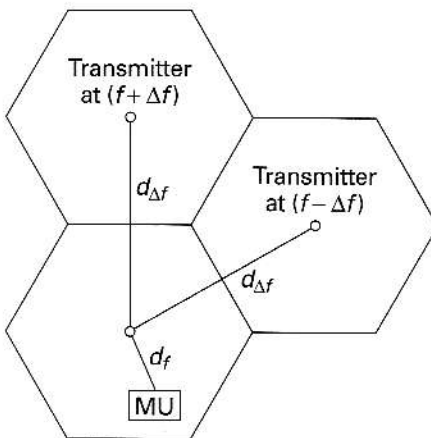

FIGURE 4.25 The MU is transmitting at a frequency of f while the ACI signals are at frequencies of $(f + \Delta f)$ and $(f - \Delta f)$. Note that ACI signals are coming from cells that are far away compared with the signal of interest, which suffers low path-dependent loss since it is closer to its own base station.

EXAMPLE 4.8

In a cellular system operating at a signal power of -85 dBm, CCI of -110 dBm is observed. If an overall signal-to-interference ratio of 20 dB is required, how much ACI can the system tolerate?

Answer

$$\text{Signal power} = 10^{8.5} \text{ mW}$$

$$\text{CCI} = 10^{-11} \text{ mW}$$

$$\left(\frac{S}{I}\right)_{\text{tot}} = 20 \text{ dB or } 100$$

$$100 = 10^{-8.5} / (\text{ACI} + 10^{-11})$$

$$\text{ACI} = 2.16 \times 10^{-11} \text{ mW or } -106.65 \text{ dBm.} \quad \blacksquare$$

4.10 SUMMARY

The concept of cells for increasing the capacity of wireless systems was described. The limitation on the performance of cells due to CCI was discussed. Performance improvement can be achieved through the use of sector antennae.

- A hexagonal structure is the optimal cell shape.
- The distance D between co-channel cells is $\sqrt{3N_c}$, where N_c is the number of cells in a pattern given by $\sqrt{i^2 + j^2 + ij}$, where i, j take values $0, 1, 2, 3, \dots$
- The signal-to-CCI ratio S/I improves as the number of cells in the pattern goes up.
- The co-channel interference reduction factor or frequency reuse factor q is given by D/R , where R is the radius of the cell. Higher values of q result in lower values of interference.
- For any pattern, the number of interfering cells is six.
- S/I is also dependent on the loss factor ν .
- An acceptable value of S/I is about 18 dB or more.
- S/I can be improved by using sector antennae.
- S/I for a 60° sector antenna $> S/I$ for a 120° sector antenna $> S/I$ for an omnidirectional antenna.
- Sector antennae reduce interference since the number of interfering cells goes down as the number of sectors goes up.
- Capacity can be increased through cell splitting.
- When cells are split to increase the coverage, the transmitted power must be reduced to keep the CCI low.
- The complexity of a microcellular system can be reduced through the use of optical fibers.
- The coverage area can be estimated by calculating the attenuation and the power margin needed to take lognormal fading into account.
- GOS is a measure of the ability of a user to gain access to a channel during the busiest period.

- Traffic intensity is expressed in Erlangs. It is given by the product of the number of calls/hour and the duration of the call (hours). For example, if a person makes an average of four calls/hour and the average duration of the call is 3 minutes, the traffic intensity generated is $4(3/60) = 0.2$ Erl.
- If the number of channels or trunks available is C , the blocking probability, $p(B)$, can be expressed as

$$p(B) = \frac{\left[\frac{A^C}{C!} \right]}{\sum_{k=0}^C A^k / k!},$$

where A is the offered traffic in Erl.

- The carried traffic A_c is given by $A[1 - p(B)]$ Erl.
- Even though co-channel interference is reduced through the use of sector antennae, the trunking efficiency is also reduced.
- Additional interference may arise from adjacent channels. ACI must be taken into account to calculate the overall interference.

PROBLEMS

- In a cellular communication system, the signal power received is -100 dBm. The structure is a seven-cell pattern. If the noise power is -119 dBm and each of the interfering signals is -121 dBm, calculate the overall signal-to-noise ratio. Also calculate the signal-to-CCI ratio.
- In a cellular communication system, the signal power received is -97 dBm. The structure is a seven-cell pattern. The noise power is -117 dBm and each of the interfering signals is -120 dBm.
 - Calculate the overall signal-to-noise ratio.
 - Calculate the signal-to-CCI ratio.
 - If a 20 dB signal-to-CCI ratio is required, what should be the power of the signal from each of the interfering cells?
- If the received power at a distance of 2 km is equal to $2 \mu\text{W}$, find the received powers at 3 km, 6 km, and 15 km for a path loss exponent ν of 3.8.
- If a mobile unit is 4 km away from the base station and 10 km away from the CCI site, find the signal-to-CCI ratio. Assume the path loss exponent ν to be 4.0.
- If a signal-to-CCI ratio has to be 20 dB and the mobile unit is 8 km away from its own base station, how far away should the CCI site be located? Assume the path loss exponent ν to be 3.2.
- A mobile unit receives a power of -105 dBm. If the predicted loss is 115 dB, what was the transmitted power?
- For acceptable performance, the signal-to-CCI ratio must be at least 20 dB. What must be the value of D/R ? Assume ν to be equal to 3.0.
- Consider the case of a Rayleigh-faded signal received by a mobile unit (MU). The threshold SNR for acceptable performance is 15 dB. Assume that the average power being received is -96 dBm. The noise power is -115 dBm. Calculate the outage probability. If the acceptable outage is only 2%, what must the noise power be to maintain acceptable performance?
- Explain the term *Erlang*.
- If a provider is planning to have 20 voice channels per cell for a grade of service (GOS) of 2%, calculate the offered traffic and carried traffic. If the provider has 10 cells, what is the total carried traffic in Erlangs?
- A provider has 75 channels in a cell. If the blocking probability is 2%, what is the offered traffic? What is the carried traffic? If each customer uses (holding time) 2 minutes and makes an average of two calls/hour, how many customers can be served?

12. Two service providers, A and B, provide cellular service in an area. Provider A has 100 cells with 20 channels/cell, and B has 35 cells with 54 channels/cell. Find the number of users that can be supported by each provider at 2% blocking if each user averages two calls/hour at an average call duration of 3 minutes.

13. A provider expects to provide coverage for about 700 users/cell. The acceptable GOS is 2%. If the user has an average holding time of 3 minutes/call and makes an average of three calls/hour, how many channels are required?

14. For the case of lognormal fading, given in eq. 2.67, use MATLAB to calculate the outage. Assume that the average power being received is -100 dBm. Standard deviation of fading = 6 dB. Threshold power = -105 dBm. Repeat the calculations for standard deviations of 8, 10, and 12 dB. Generate either lognormal or normal random numbers (at least 5000) to compute the outage probability.

15. Instead of using the random number generator from MATLAB, use the analytical approach to calculate outage probability. Compare your results to the values calculated in Problem 14.

16. Use MATLAB to generate 1000 Rayleigh-distributed random variables such that the average signal power is 0 dBm. If the threshold is -3 dBm, compute the outage probability. Repeat the simulation for a threshold of -5 dBm.

17. Use the analytical approach to calculate the outage for the cases in Problem 16, and compare your results.

18. The transmit power of a base station is 2 W. If the coverage is to be split so that minicells (one-third size) can be created to accommodate additional users in the geographical region, what must be the transmit power (of the minicell) to keep CCI at the same level as that of the unsplit cell? Assume that $\nu = 3.0$.

19. To keep an acceptable level of performance, a service provider is planning to maintain an outage probability of 3%. What should be the threshold power? The standard deviation of fading (lognormal) has been found to be 8 dB. The average received power is -95 dBm.

20. Based on the Hata model for power loss, it has been determined that there is approximately 0.7 dB/km loss in the range of 10–18 km from the transmitter. The long-term fading margin is 6 dB and the short-term fading margin is 4 dB. Calculate the reduction in transmission distance when

- (a) Only the long-term fading margin is factored in.
- (b) Only the short-term fading margin is factored in.
- (c) Both fading margins are taken into account.

21. Use MATLAB to plot the outage probability at the edge of a cell as a function of the power margin.

22. Use MATLAB to plot the area outage probability as a function of the power margin. Comment on the relative variation of the outage probabilities (for this problem and Problem 21) for the two power margin values 6 dB and 10 dB.

23. Use MATLAB to calculate the maximum distance using your calculations from Problem 21 for two outage probabilities, 0.1 and 0.05. Assume that the standard deviation of fading (lognormal) is 6 dB. The path loss exponent is 3.5. The received power at a distance of 4 km from the base station is -50 dBm. The threshold level for performance is -91 dBm.

24. Consider a seven-cell pattern that uses an omnidirectional antenna with 54 channels/sector. Calculate the trunking efficiency if

- (a) A 60° sector antenna is used.
- (b) A 120° sector antenna is used.

25. Explain the term *adjacent channel interference*. If the signal power received is -90 dBm, the CCI power/channel is -120 dBm, and the ACI is -110 dBm, calculate the overall signal-to-noise ratio. Note that thermal noise has been neglected.

26. Outage probabilities have been calculated for Rayleigh channels assuming that the co-channel power is constant. However, the co-channel signal also undergoes Rayleigh fading, and this must be taken into account. If our requirement for acceptable co-channel interference is that the ratio of the signal power to the co-channel signal power be α dB, derive an expression for the outage probability arising from co-channel interference.

27. Use MATLAB to obtain a plot of outage probability for various values of the “protection ratio” α .

28. Repeat Problem 26 if the desired signal and the CCI are subject to lognormal fading. Assume that the standard deviations of fading are same for both the desired and CCI signals.

29. Use MATLAB to obtain plots of the outage probability as a function of the “protection ratio” α for different values of the standard deviation of fading.

30. Using a random number generator, repeat Problem 26.

31. Repeat Problem 28 using a random number generator.