

Patch Antennas

UNIK9700 Radio and Mobility

*Johan Tresvig
PhD Candidate
Dept. of Physics, UiO
j.l.tresvig@fys.uio.no*

Outline

- Introduction – Patch antennas
- Theory - Rectangular patch antenna
- Case study – Design of a patch antenna

Microstrip Antennas

- First proposed in 1953
- Commercialized in the 70s
- Inexpensive
- Compatible to PCB
- Easy to manufacture
- Low profile
- Used in the $>1\text{GHz}$ range



Meandering Monopole antenna

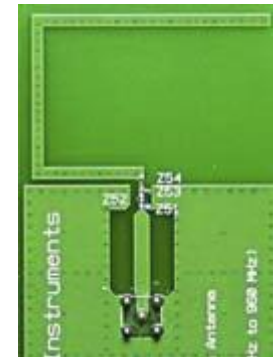

Loaded Stub Antenna

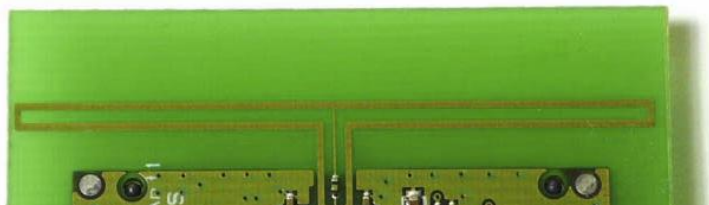

Folded Dipole antenna

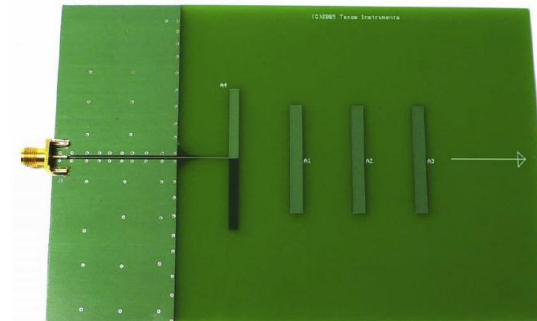

YAGI antenna

Rectangular Patch Antenna

- Popular type of microstrip antenna

- High gain
- Wide beam
- Lower efficiency
- Lower bandwidth

- Antenna bandwidth

- Measured in % -> $\% = \frac{BW}{f_0}$
- increases with substrate thickness
- decreases with substrate permittivity
- Efficiency decreases with substrate permittivity
- WLAN uses air as substrate

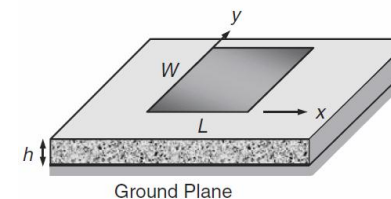
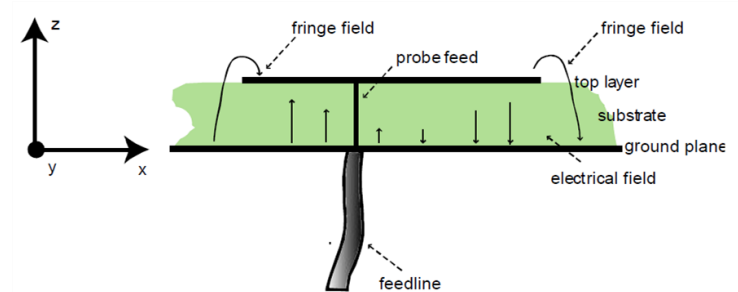

Rectangular Patch Antenna

- Calculating the antenna dimensions

- $L = 0.49\lambda_d = \frac{\lambda_0}{\sqrt{\epsilon_r}}$

- $\frac{W}{L} = 1.5$

- $f_0 = \frac{c}{2(L+2\Delta L)\sqrt{\epsilon_r}}$, where $\Delta L = f(h, W)$

Resonance frequency (f_0) is influenced by:

- ground plane size
- copper thickness
- Impedance width

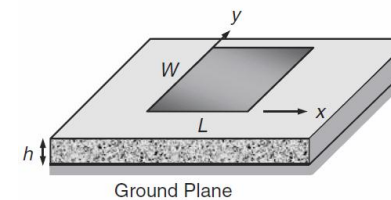
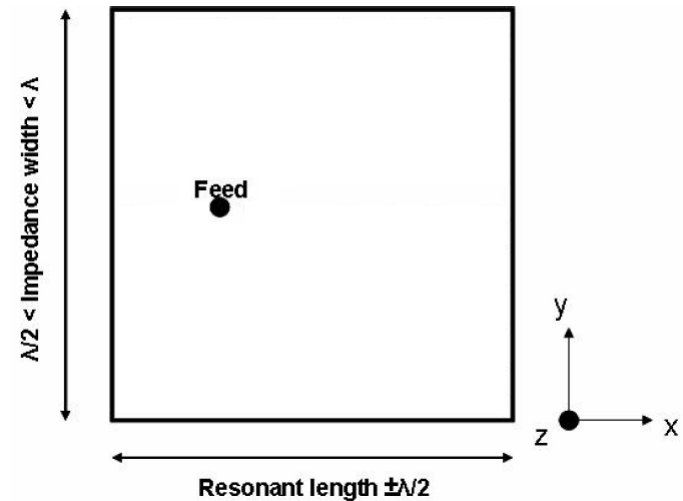

Signal Feeding

- Coaxial probe feed (a)
 - Simple feed
 - Probe reactance must be considered
 - Used for standalone antennas
- Inset feed (b)
 - Used for antenna arrays
 - Allows for more flexible impedance matching
- Proximity feed (c)
 - More complex
 - Reduces emissions from the feed line
- Aperture feed (d)
 - reduces radiation from feed line
 - Some back radiation
 - Probe reactance not an issue

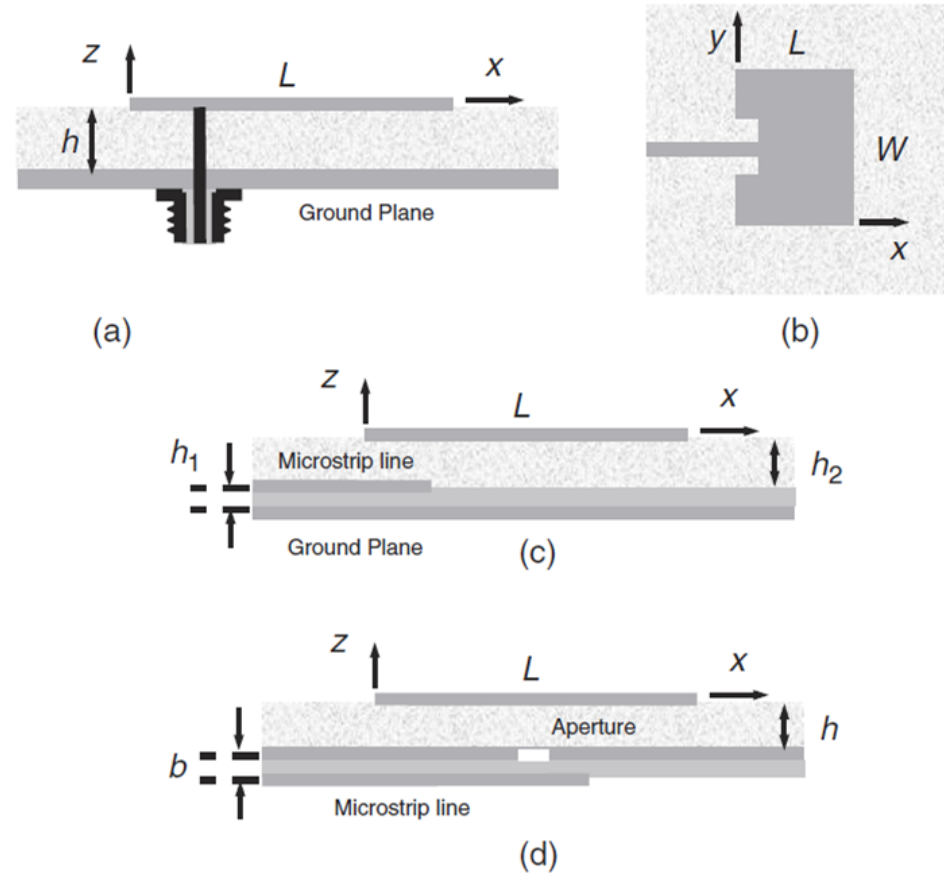

TEM - Mode

- Transversal Electro Magnetic (TEM_{xyz}) field distribution
- Patch antennas denoted TM_{10} using cavity theory

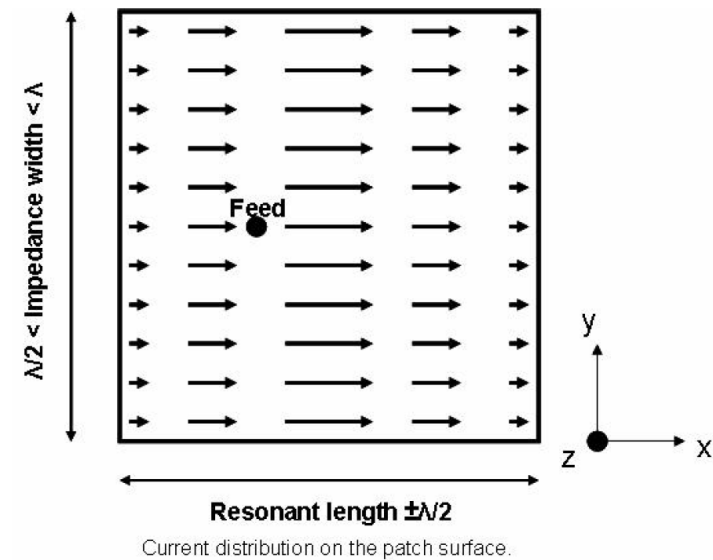
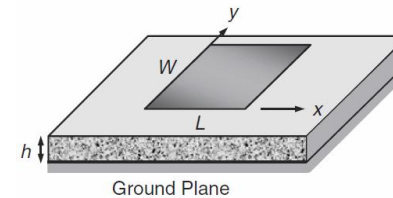

CAD model

- Patch cavity resonator
 - CAD modeling
 - Simplified model of a patch antenna
 - Applicable for patch antennas with a thin substrate
 - CAD modeling can be used when antenna complies with TM_{10}

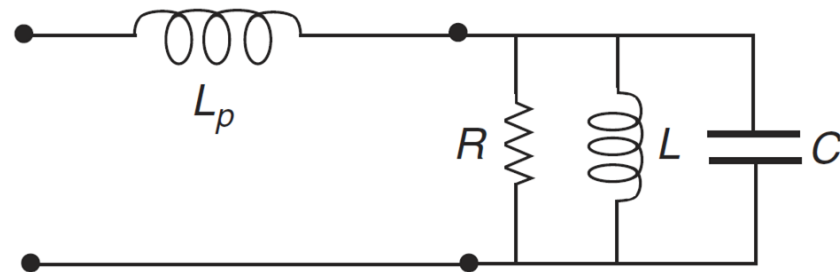

Circular Polarization

- Signal split in two
- Vertical and horizontal radiator
- One feed phase shifted by 90 Deg.

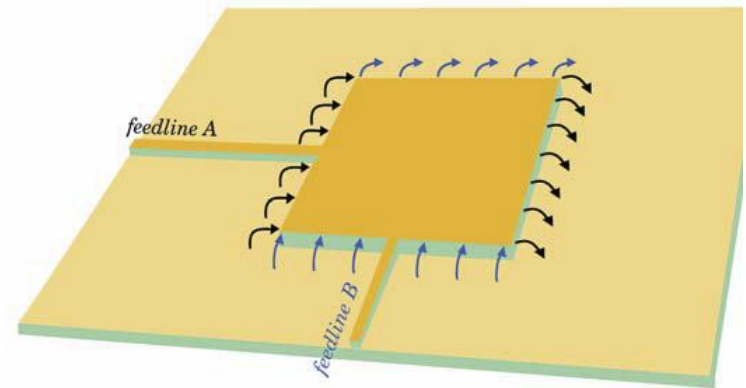
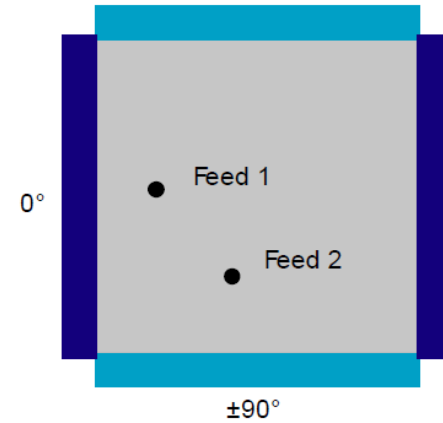

STAR

Space Technology And Research center

- Cooperation between the Space- and Plasma Physics group and Electronics group
- Investigate plasma density and turbulence in the ionosphere
- Mitigate satellite communication outage
- multi-Needle Langmuir Probe (m-NLP)

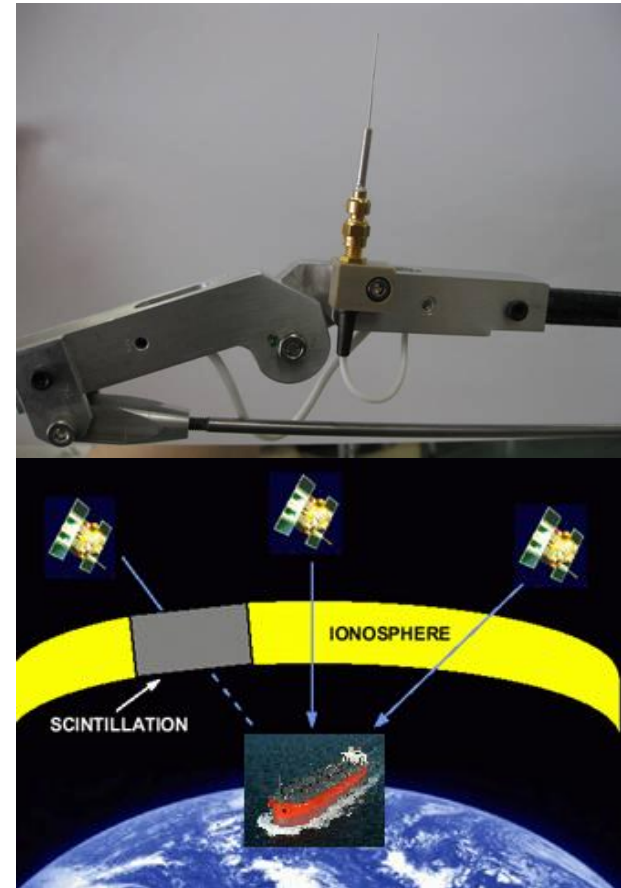

(Top): A needle Langmuir probe.
(Bottom): GPS signal interference induced by scintillation in the ionosphere

Sub-Payload Concept

- Deployable sensor platform for sounding rockets
- Objective is to increase data points on electron density measurements
- Receiver system employs Frequency Division Multiple Access (FDMA) to gather data from all sub-payloads simultaneously
- Received data is encoded into the rockets telemetry system and forwarded to ground

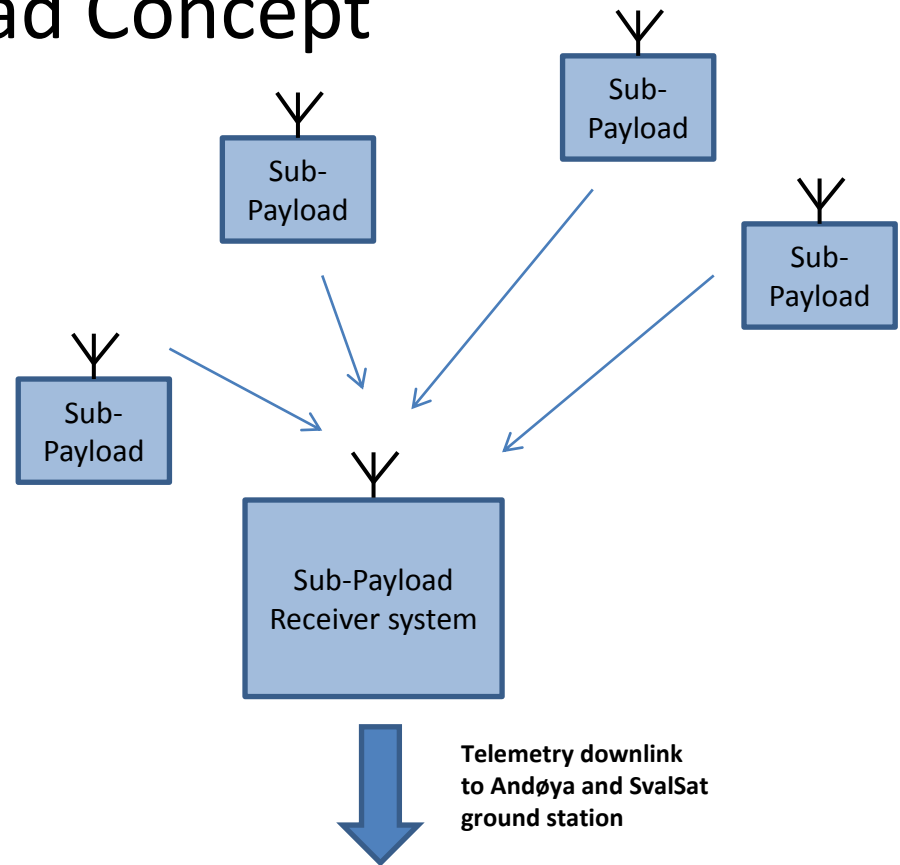

Sub-Payload

- Sensors

- M-NLP
- Gyro
- Magnetometer

- Data budget

- Data rate: $\sim 200\text{Kbit/s}$
- Coverage: $< 2000\text{m}$

- Radio link

- 250kbaud
- Minimum Shift Keying (MSK) modulation scheme

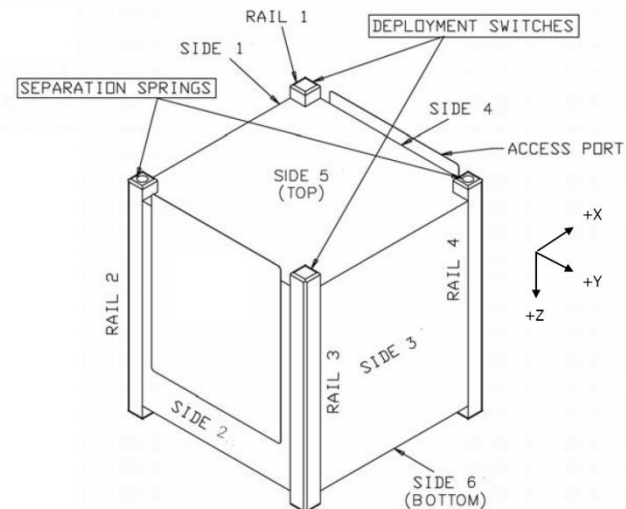
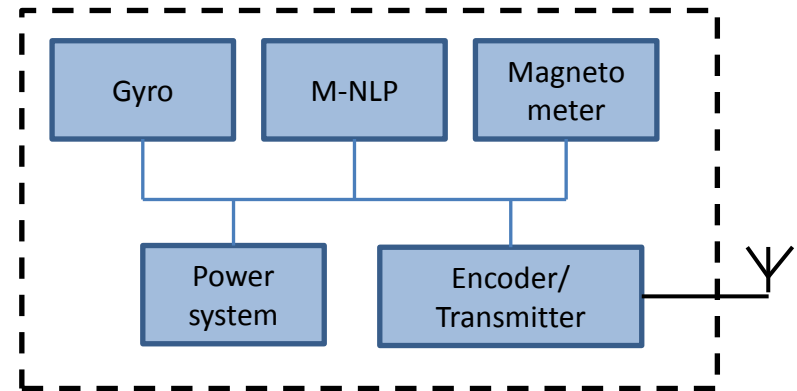

Sub-Payload Antenna Measurements

- Antenna coverage
- Receiver antenna: constrained by the launch team at Andøya Rocket Range (ARR)
- Selected preferred antennas from ARR
 - Polarization: Linear
 - Gain: 0 – 3dB



Receiver antenna

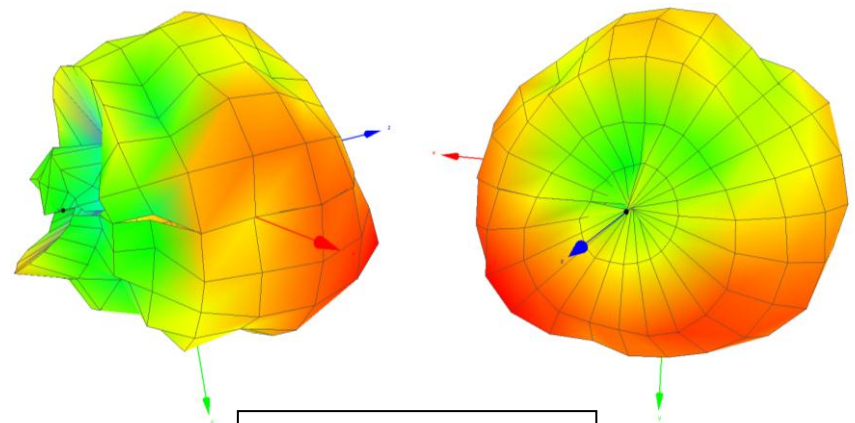

Measured radiation pattern

MAxiDusty Campaign

- Rocket campaign from Andøya Rocket Range (ARR)
- Timetable:
 - 1. Hardware integration Jan.2013
 - 2. Hardware integration April 2013
 - Launch Aug. 2013
- Objectives
 - Perform proof of concept
 - Perform 3D ion density measurements

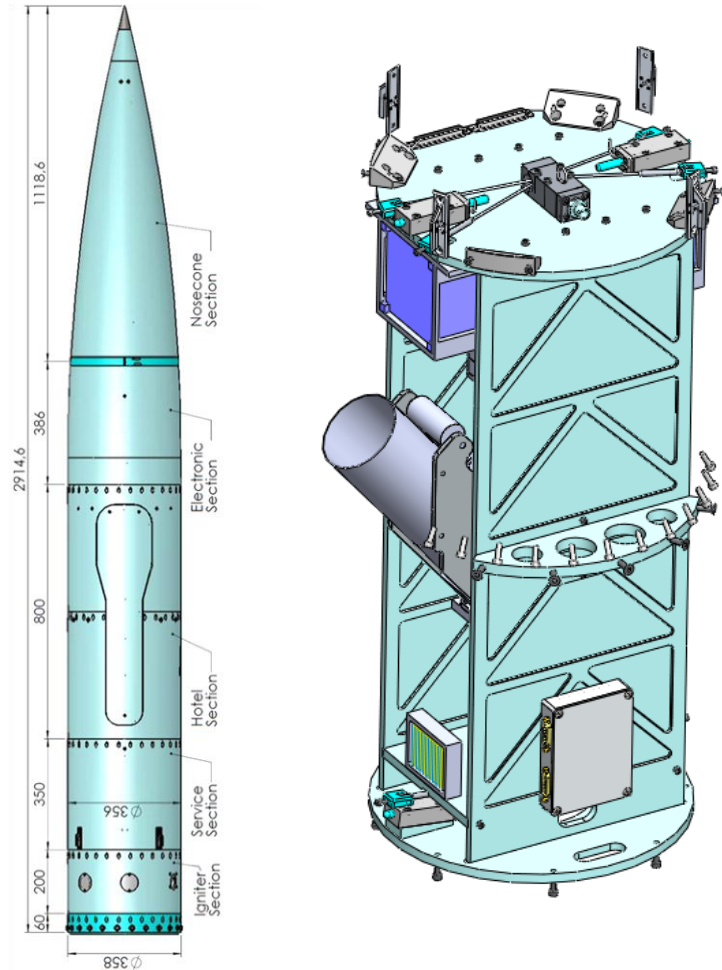

CAD model of MaxiDusty and the Hotel section

Sub-Payload Patch Antenna

- Low profile
- Half-Sphere radiation pattern
- Circular polarization
- Mounted on opposite sides of the sub-payload
- Antenna design
 - Multiphysics simulation tool
 - Measurements in antenna chamber

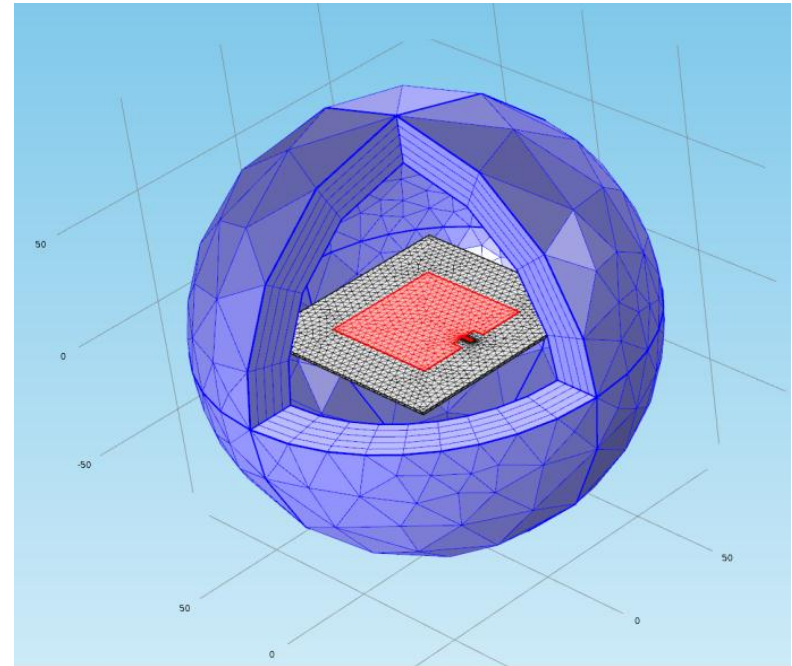

CAD simulation model of the patch antenna

Sub-Payload Patch Antenna

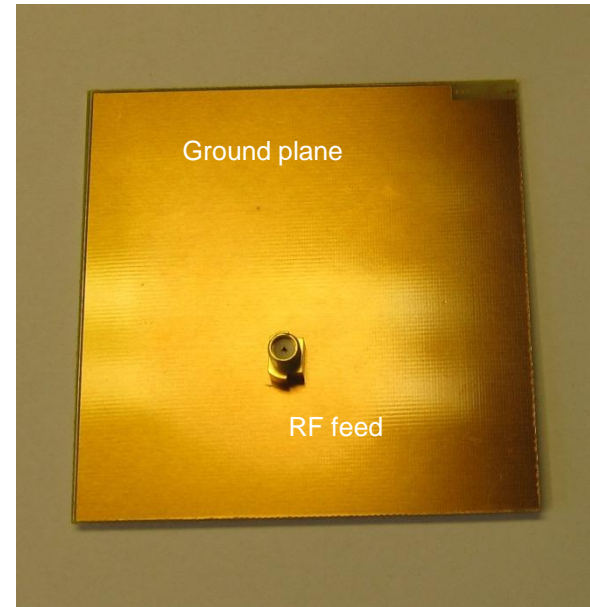
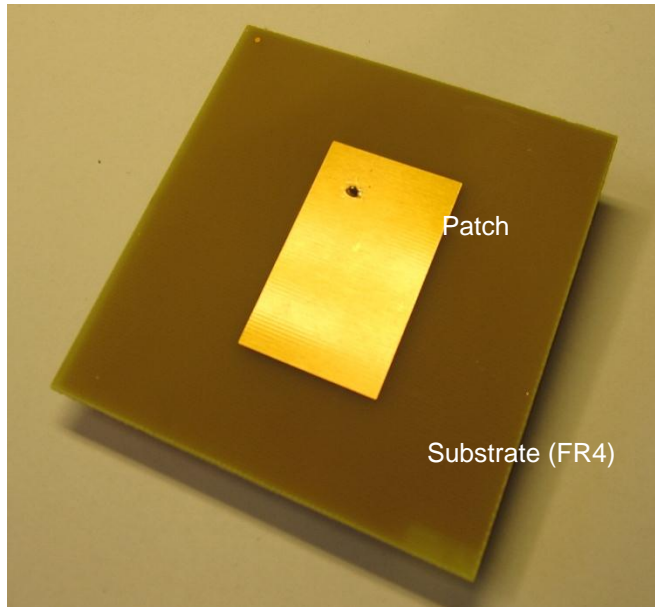

- $L = 0.49\lambda_d = 0.49 \frac{\lambda_0}{\sqrt{\epsilon_r}} = 0.49 \frac{12.5cm}{\sqrt{4.5}} = \underline{2.88cm}$
- $\frac{W}{L} = 1.5 \rightarrow W = 1.5 \times 2.88cm = \underline{4.33cm}$

Patch Antenna Measurements



Trc1 S22 Smith Ref 1 U

S22

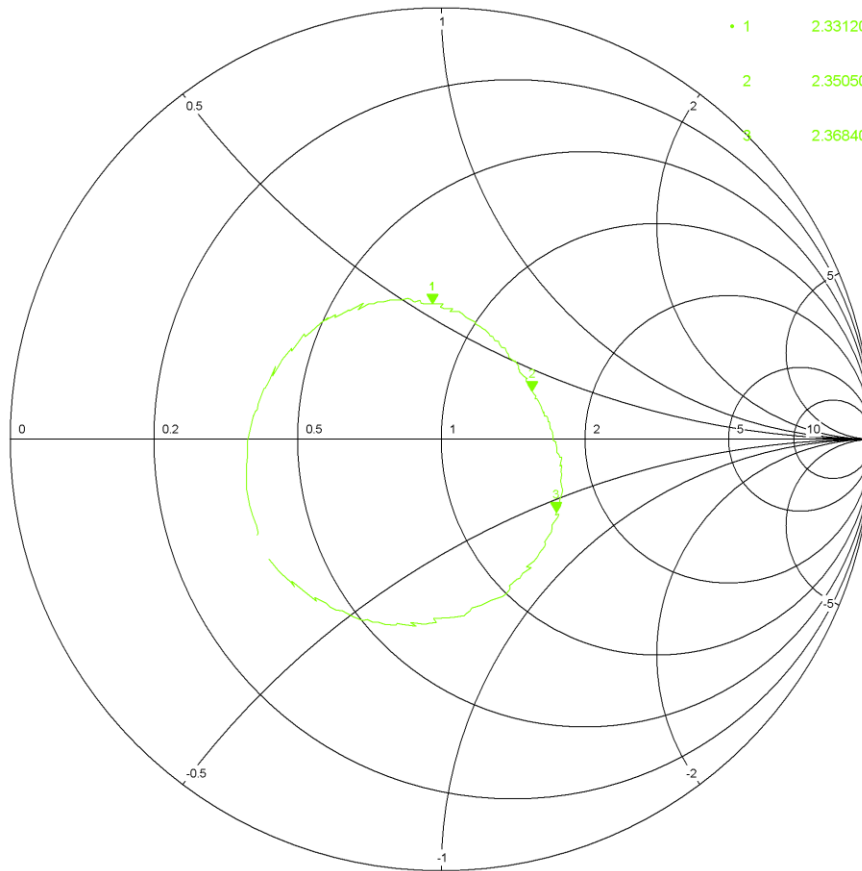

Point	Frequency (GHz)	Real (Ω)	Imaginary (Ω)	Inductance (nH)	Capacitance (pF)
1	2.331200	39.482	j27.565	1.882	
2	2.350500	74.142	j17.611	1.192	
3	2.368400	79.572	-j30.026		2.238

$$Z_L = 39.5 + j27.6\Omega$$

$$Z_C = 74. + j17.6\Omega$$

$$Z_U = 79.6 - j30.0\Omega$$

Ch1 Center 2.3505 GHz

Pwr -10 dBm

Span 90 MHz

Date: 15.NOV.2012 12:18:22

Impedance measurements

Patch Antenna Measurements

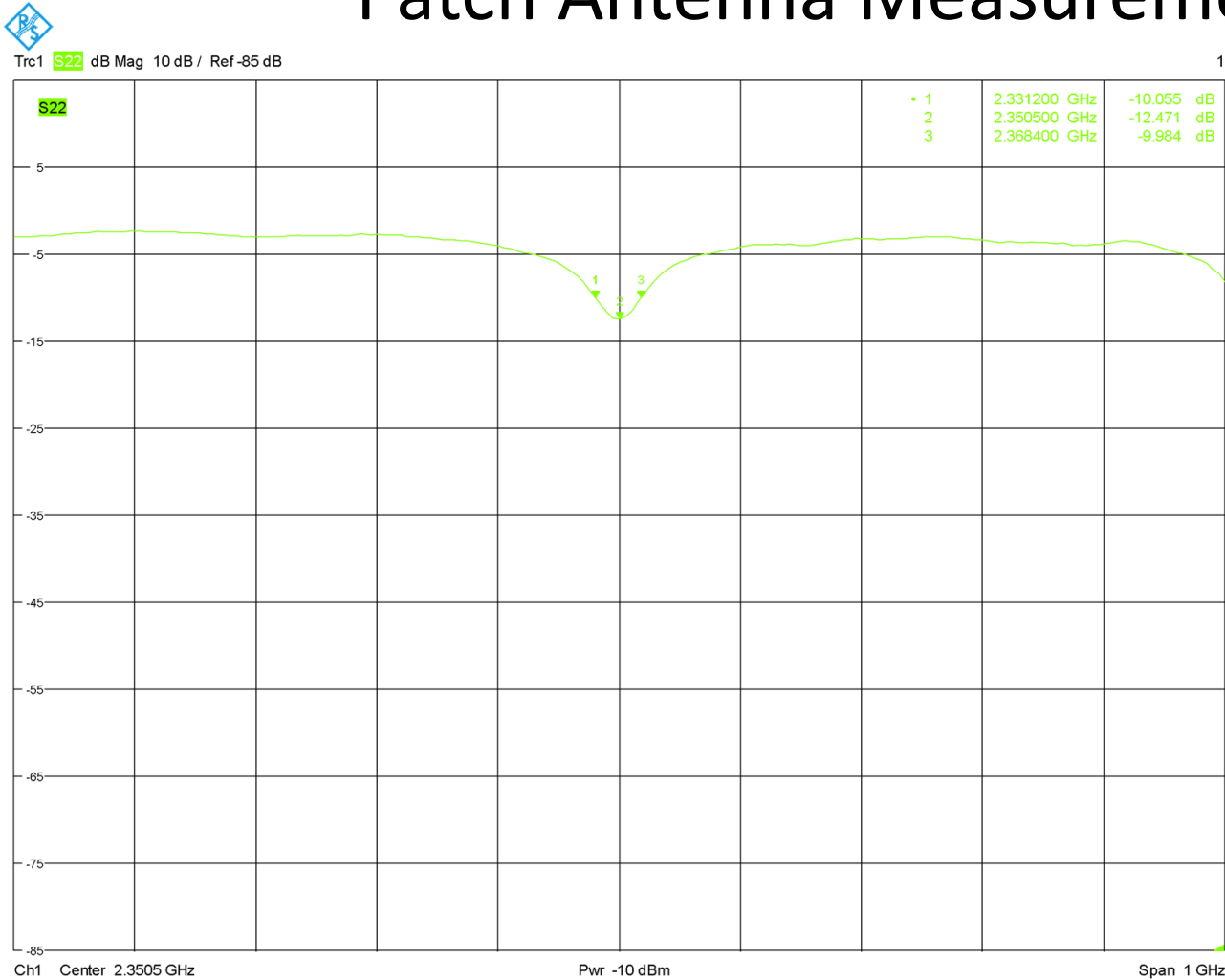

$$BW = 37MHz$$

$$B(\%) = \frac{37MHz}{2350MH} \times 100\%$$

$$B(\%) = 1.67\%$$

Bandwidth measurement

References

- [1] *The Basic of Patch Antennas*, D. Orban & G.J.K. Moernaut, Orban Microwave Inc
- [2] *Antenna Engineering Handbook*, Chapter 7, D.R. Jackson, McGraw-Hill Inc
- [3] *The Fundamentals of Patch Antenna Design and Performance*, G. Breed, High Frequency Design, p.48-50
- [4] *CAD OF RECTANGULAR MICROSTRIP ANTENNAS*, D.R. Jackson et al

Questions?