



UNIK4230: Mobile Communications

Spring Semester, 2014

Abul Kaosher

abul.kaosher@nsn.com

Mobile: 99 27 10 19

Tentative lecture schedule- UNIK4230

Spring Semester, 2014

- ❑ 30. Jan. 2014 Introduction
- ❑ 06. Feb. 2014 Network Architecture and Functionality
- ❑ 13. Feb. 2014 Propagation Characteristics of Wireless Channel-I
- ❑ 20. Feb. 2014 Winter break
- ❑ 27. Feb. 2014 Propagation Characteristics of Wireless Channel-II
- ❑ 06. Mar. 2014 Combating the effect of Fading in Mobile Systems
- ❑ 13. Mar. 2014 Cell and Cellular Traffic-I
- ❑ 20. Mar. 2014 Cell and Cellular Traffic-II
- ❑ 27. Mar. 2014 Multiple Access
- ❑ 03. April. 2014 Students Seminar on selected topics (All)
- ❑ 10. April. 2014 Mobile Broadband-I (Market Trends, Evolution, LTE)
- ❑ 17. April. 2014 Easter holiday
- ❑ 24. April. 2014 Mobile Broadband-II (LTE, SON, QoS, LTE-A)
- ❑ 08. May. 2014 Refarming and the challenges of Mobile Communications
- ❑ 15. May 2014 Small Cell and Heterogeneous Network (HetNet)
- ❑ 22. May 2014 Repetition and walk through on the course including Exam guidance
- ❑ 05, June 2014 Examination

Reference literature & examination

Lecture slides (will be uploaded before lectures)

Book

- P. M. Shankar, *Introduction to Wireless Systems*, 2002, Wiley.
 - Syllabus: chapter 2, 3, 4, 5 & 6
 - Do you need a copy of the chapters?
- Harri Holma and Antti Toskala, *LTE for UMTS. Evolution to LTE-Advanced*. 2nd Edition.

Articles

- Will be provided during lectures (when necessary)

Examination type:

- Oral examination (based on lecture slides, chapters of the course book, articles provided during lectures); if book chapter discusses more, contents in the lecture slide will limit the syllabus; however, lecture slides may contain more topics than the book chapter. In that case, follow the extra topics only from the slides and the articles (if given).

Assignments

- Presentation on selected topics

Introduction

Date: 30.01.2014

Importance of Telecommunication

Telekom er viktigere enn strøm og vei

Jeg ble veldig overasket da jeg forsto for første gang at telekommunikasjon er viktigere enn strøm og vei. Vi kan klare oss uten strøm og vei, men telekom kan vi ikke klare oss uten.

-Torstein Olsen, direktør i Post- og teletilsynet informerte

-Source: dn.no. Publisert: 13.01.2012 - 16:40 Oppdatert

Importance of Telecommunication

- Mobile Communications industry contributes to between 3.7 percent and 6.2 percent of GDP in the Telenor markets in Bangladesh, Pakistan, Thailand, Serbia and Ukraine.
- An increase of 10 percent in mobile penetration will boost the annual economic growth rate of a developing country by 1.2 percent.

according to a study by Deloitte for Telenor in Bangladesh, Pakistan, Thailand, Serbia and Ukraine in 2008

Agenda

- What is mobile communication?
- History and trends
- Elements in mobile communication systems
- Basic functionality

Agenda

- What is mobile communication?
- History and trends
- Elements in mobile communication systems
- Basic functionality

What is mobile communication?

- Mobile communication system allows communication to and from handheld terminals during movement
- The system can handle a large number of users and provides almost a continuous coverage in a large geographical area
- Base station provides an area coverage
- The system has underlying infrastructure that provides communication to/from other type of communication networks

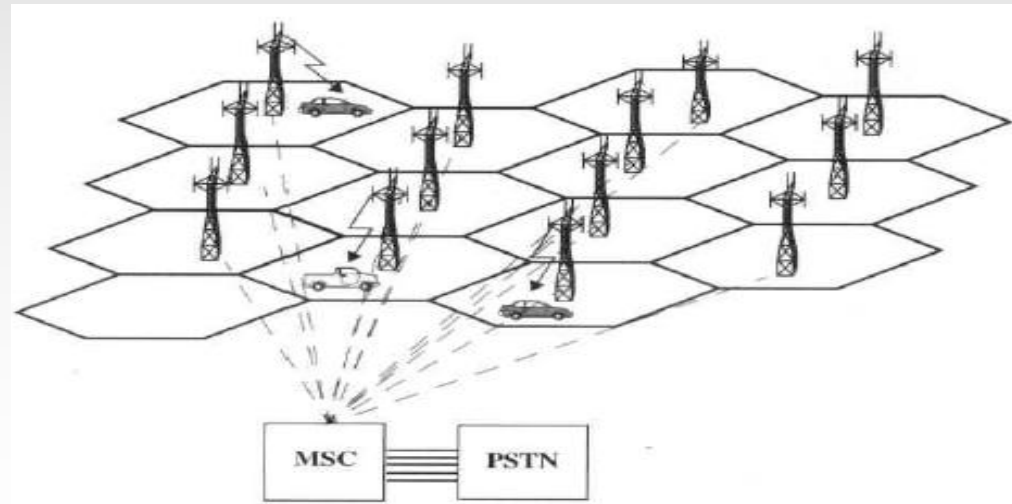

Mobile Communication

- Mobile Device is most personalized device
- Voice, SMS
- Data/Internet
- Emergency (police, ambulance, fire)
- Payment
- M2M communication
- Entertainment (music, gaming)
- Social Network and life

Generations in Mobile communication

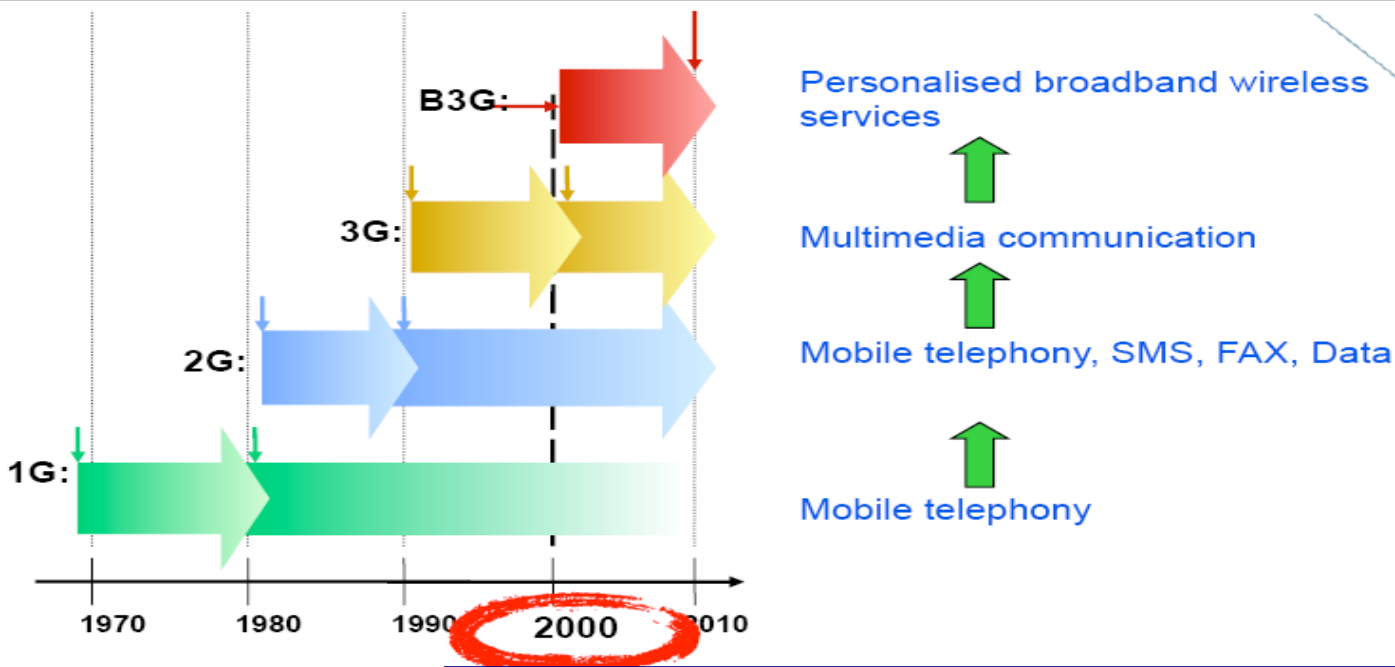

Original: B3G study, Jan 2001

4G

100 Mbit/s for high mobility communication
1 Gbit/s low mobility communication
LTE wont fulfill ITU-R requirements
Candidate: LTE-A
Service e.g. Mobile broadband

1G

Analog communication
Only voice
e.g NMT-450, AMPS

2G

Digital communication
Mostly voice service, data service limited and low speed
e.g. GSM

3G

Simultaneous voice and data
peak data rate at least 200 kbps (IMT-2000 specs.)
Latest UMTS release HSPA+ (Evolved HSPS): upto 84Mbit/s (DL), upto 22 Mbit/s (UL) -> 3.75G?

Generations in Mobile Communications

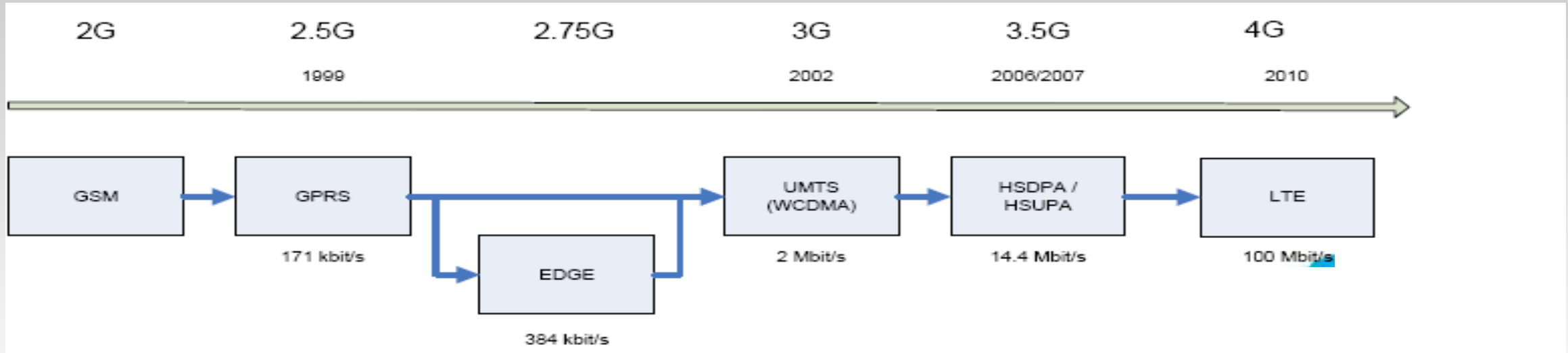

Generations in Mobile Communications

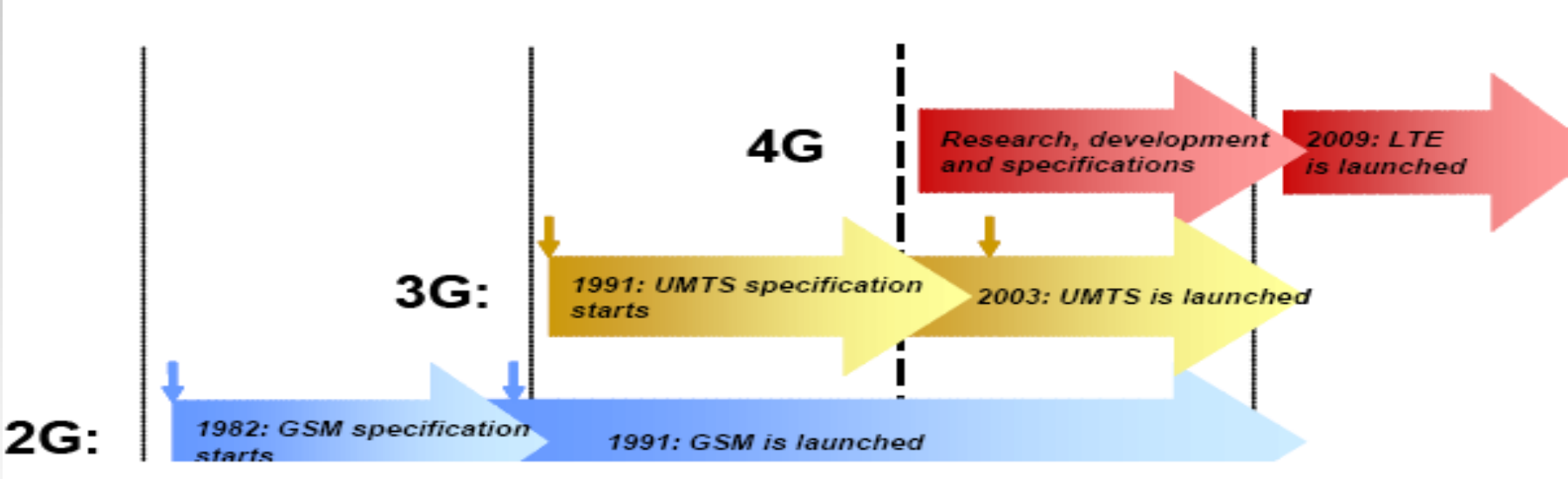

Frequency band, technologies & operators

	Frekvens- bånd	Total mengde tilgjengelig	Bruk i Norge (forventet bruk)	Aktører i Norge
450 MHz	453-457 463-467	2*4 MHz	CDMA	"ICE"
DD (800 MHz)	790-820 832-862	2*30 MHz	(LTE)	(frekvenser ikke delt ut)
900 MHz	880-915 925-960	2*35 MHz	GSM	Netcom/ Telenor
1800 MHz	1710-1805 1805-1880	2*75 MHz	GSM	Netcom/ Telenor/ Network Norway
2100 MHz	1920-1980 2110-2190	2*60 MHz	UMTS	Netcom/ Telenor
2600 MHz	2500-2570 2620-2690	2*70 MHz	LTE	Netcom



Agenda

- What is mobile communication?
- **History and trends**
- Elements in mobile communication systems
- Basic functionality

History: Bell lab was testing mobile radio telephone in 1924



© Bell Labs

History

- According to Bell Labs, on June 17, 1946, the first mobile telephone call was placed in St. Louis, Missouri from a telephone set installed in an automobile.
- In 1947 AT&T introduced **Mobile Telephone Service (MTS)**. Extended to 100 towns and highway corridors by 1948.
 - Only 5,000 customers placing about 30,000 calls each week. Calls were set up manually by an operator and the user had to depress a button on the handset to talk and release the button to listen.
 - 3 radio channels were available and hence 3 persons in any given city could make mobile telephone calls at one time
- In 1965 AT&T introduced **Improved Mobile Telephone Service (IMTS)**.
 - more simultaneous calls in a given geographic area, customer dialing, eliminating manual call set by an operator, and reduced the size and weight of the subscriber equipment

History: Cellular principle

- In December 1947, Douglas H. Ring and W. Rae Young of Bell Labs, proposed hexagonal cells for mobile phones in vehicles.
- No technology was available to implement those until 1960
- There were no continuity of services between several cells in that early implementation
- The concept of *frequency reuse* and *handoff* was introduced later in 1970's.

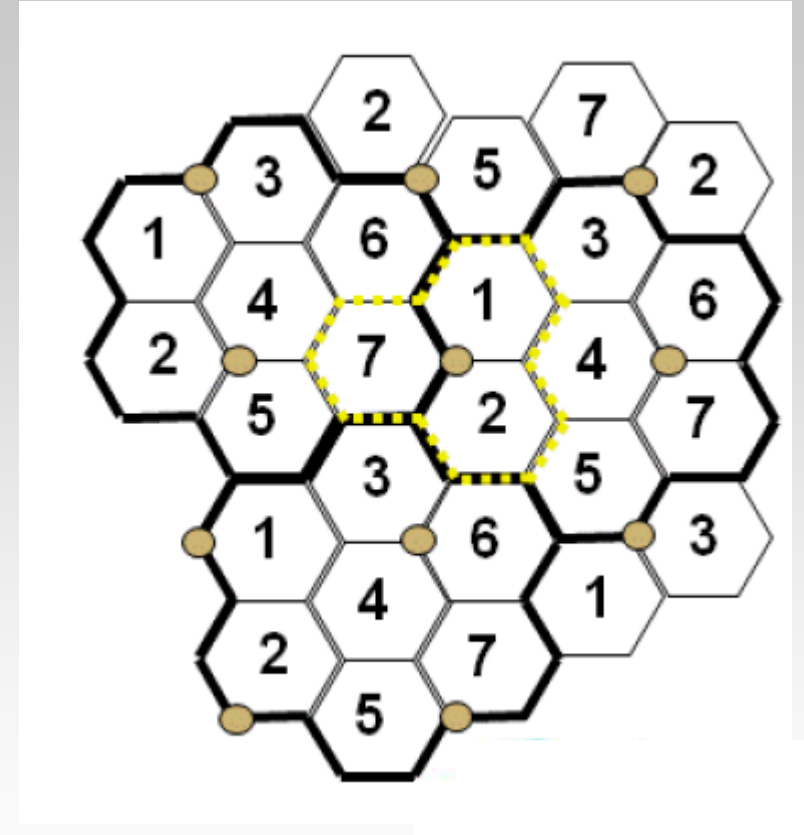

History- NMT

- NMT was first tested in Stockholm between 1975-1979
- In October 1981, Nordic countries (Norway, Sweden, Denmark, Finland, Iceland) opened NMT network with automatic roaming between countries
- In Norway 250-300 BTS were expected to provide land coverage
- Initially capacity was 35000 subscriber that could be increased to 140000
- The first mobile phone weighed about 17 kg and cost was 35000 kr!



History- NMT

- In 1984 NMT started facing capacity problem
- In 1986 NMT-450 had 87000 subscription in Norway
- To increase capacity, NMT later rolled out NMT 900 MHz band
- In 1995, two years after the start of GSM, NMT subscriber number peaked and there were 488 000 NMT subscribers in Norway
- Finally NMT were laid down in 2005, a month after 3G network was opened in Norway

History- GSM

- In 1982, the Conference of European Posts and Telegraphs (CEPT) formed an Groupe Spécial Mobile (GSM) study group to develop a pan-European public land mobile system
- In 1987, 15 representatives from 13 European countries signed a memorandum of understanding to develop and deploy a common cellular telephone system
- In 1990, the Phase I of the GSM specifications for voice and Short Messaging Services (SMS) were published by ETSI
- In 1991, First commercial network launched by Radiolinja (Elisa Finland)



1991: Radiolinja (now Elisa) the first GSM Network in Finland. Mr. Harri Holkeri, then prime minister of Finland made the first GSM call.

History- GSM

1993: Tele-Mobil (Telenor Mobil) and NetCom GSM opens their networks in Norway

1998: GSM 1800 starts operation to increase the network capacity in cities in Norway

2001: GPRS service started by Telenor Mobil

2004: EDGE Service started in Norway

2003: First 3G service in Europe

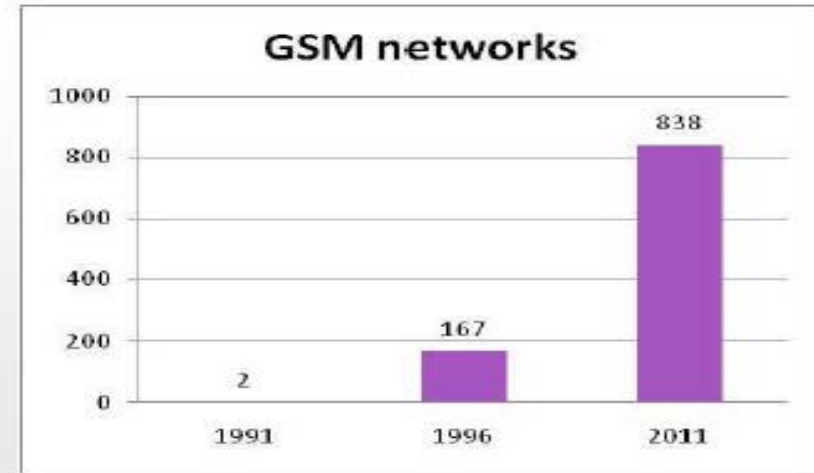
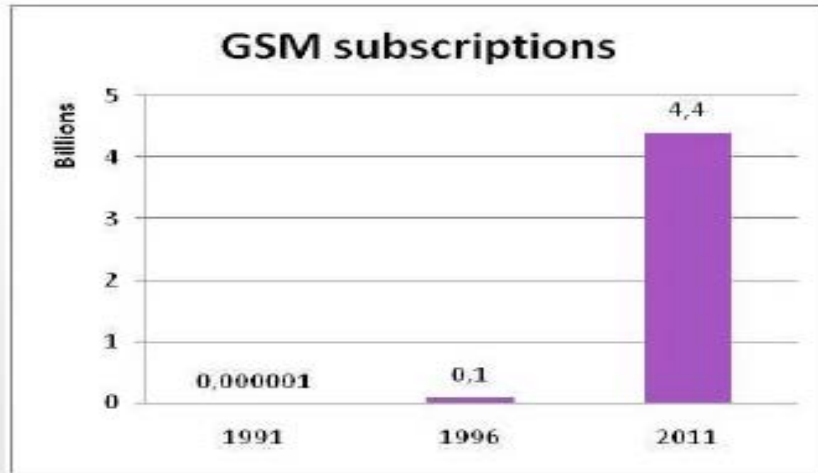

Regulation & standardization

National & International regulators decide to use different frequency band for different applications. The most important regulatory bodies are:

- Post & Telecommunication Authority, regulatory authority in Norway
- CEPT (Conference of European Post and Telecommunications Administrations)
- ITU-R (International Telecommunication Union – Radio Communication), international regulatory authority arrange WRC (World Radio Communication Conference)

Standard organizations develop and adopt international standards for telecommunication systems, most important bodies are:

- ETSI (European Telecommunication Standard Institute), developed GSM standards
- ITU-T (International Telecommunication Union Standardization Sector), part of the ITU standardization
- 3GPP (3rd Generation Partnership Project), cooperation between regional standardization body of Europe, North America and Asia; responsible for all standardization of 3G and GSM development

Where we are today



Trends: Mobile subscriptions

6.6 BILLION
mobile subscriptions
globally in Q3 2013

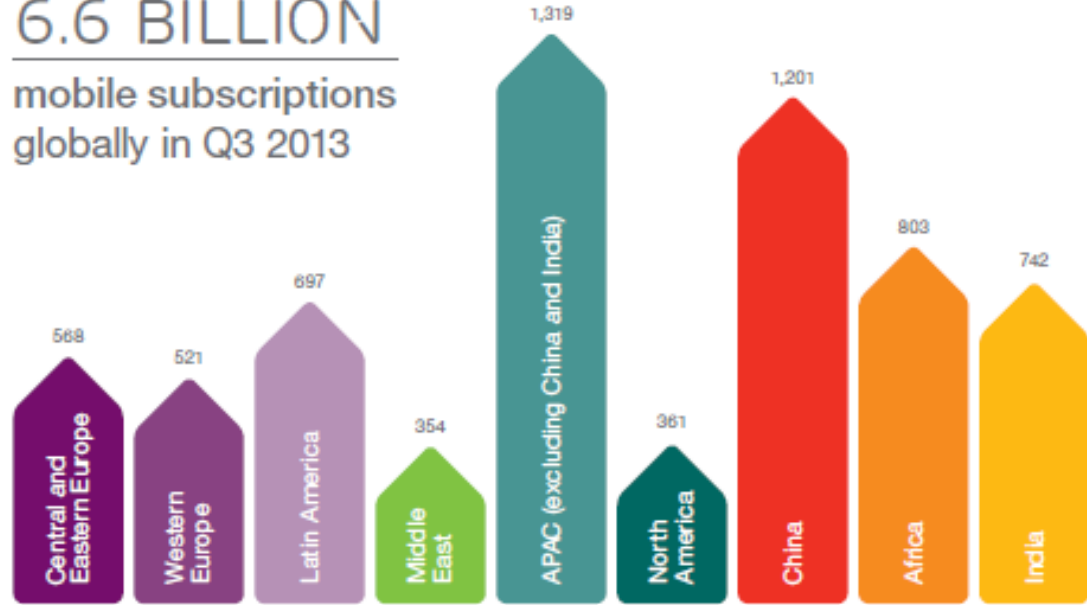

Mobile subscriptions (million)



Global mobile broadband subscriptions will exceed 2 billion in 2013

Subscriptions/lines (billion)

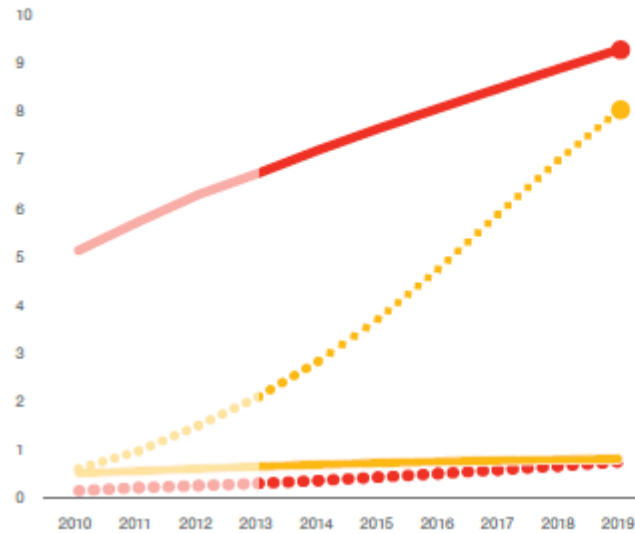

9.3 BILLION
mobile subscriptions by
the end of 2019

4X
growth in mobile
broadband subscriptions
between 2013 and 2019

- Mobile subscriptions
- Fixed broadband subscriptions
- Mobile broadband subscriptions
- Mobile PCs, tablets and mobile router subscriptions

Mobile subscriptions (billion)

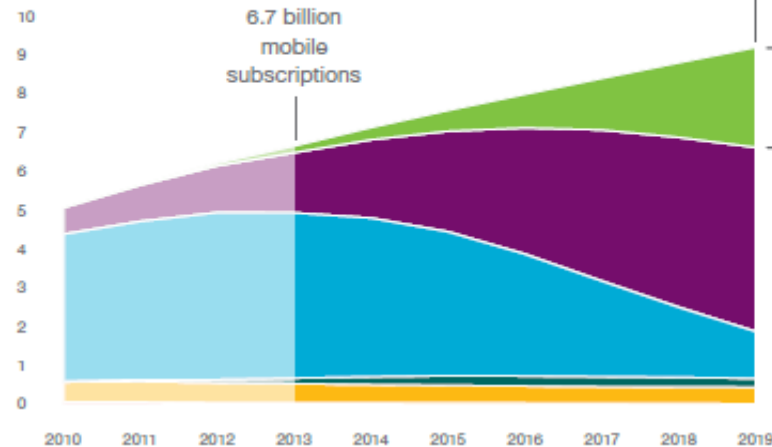

2.6 BILLION
LTE subscriptions
by the end of 2019

- LTE/HSPA/GSM and LTE/CDMA
- HSPA/GSM
- GSM/EDGE-only
- TD-SCDMA/GSM
- CDMA-only
- Other

Mobile Subscription and technology per region

85%

of North American mobile subscriptions will be LTE by 2019

80%

of Middle East & Africa subscriptions are 2G in 2013. The same number will be 3G/4G in 2019

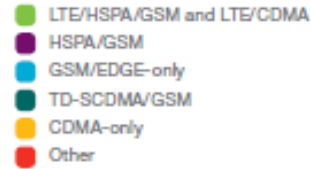

Mobile subscriptions

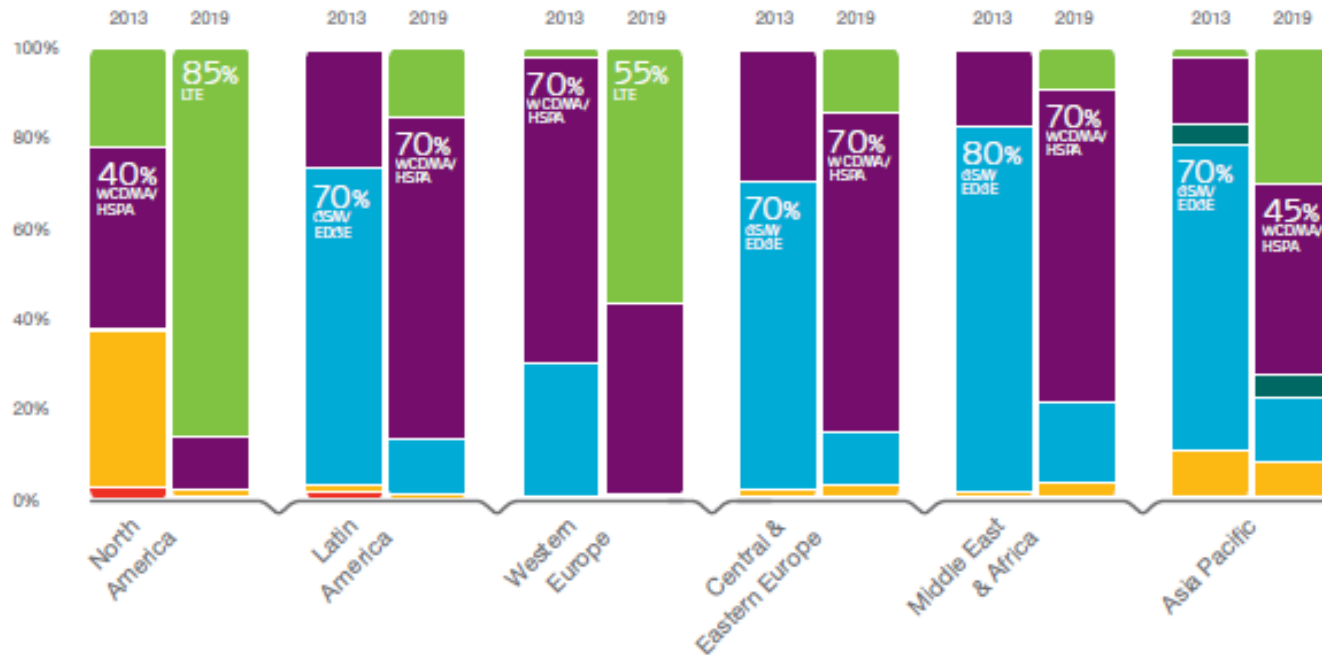

Take away-

- 3GPP technologies (GSM, WCDMA/HSPA, LTE) are dominant ones
- Going forward, main growth will be in WCDMA/HSPA and LTE technology

Trend: Traffic development

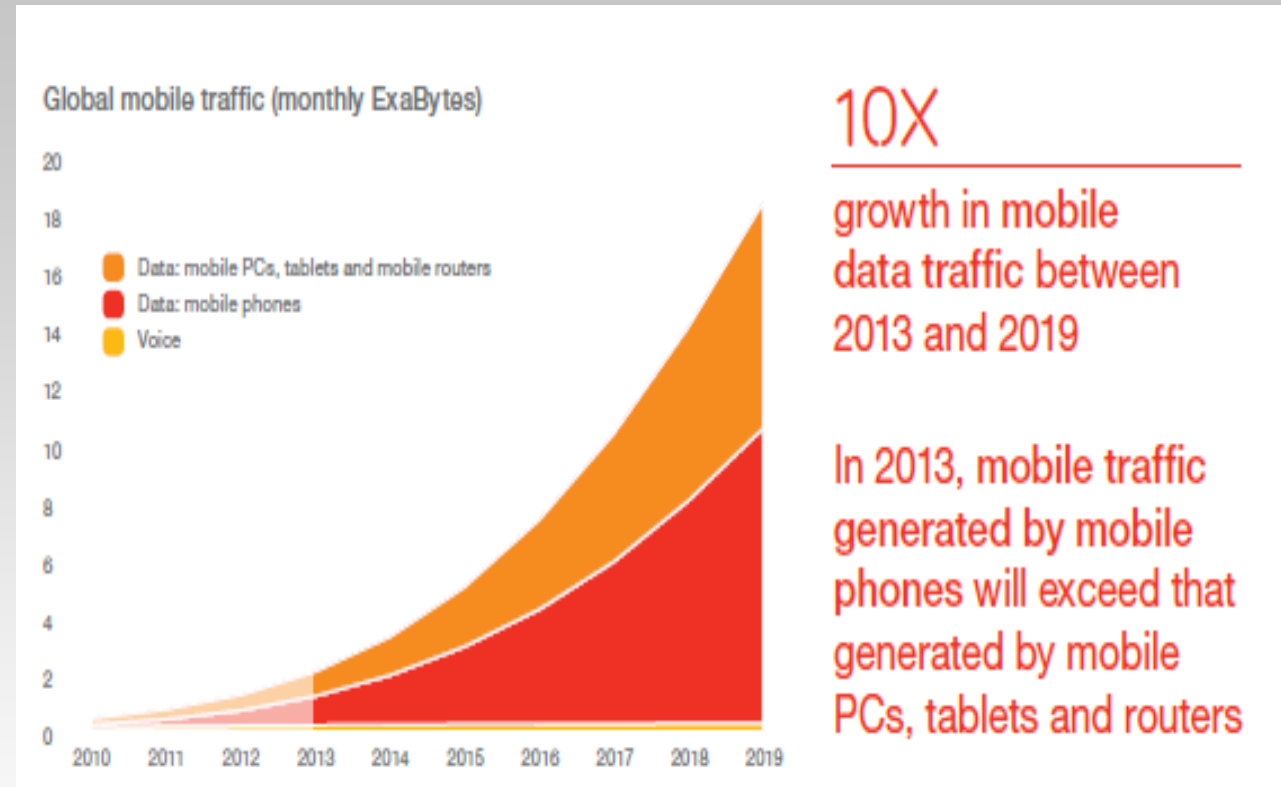
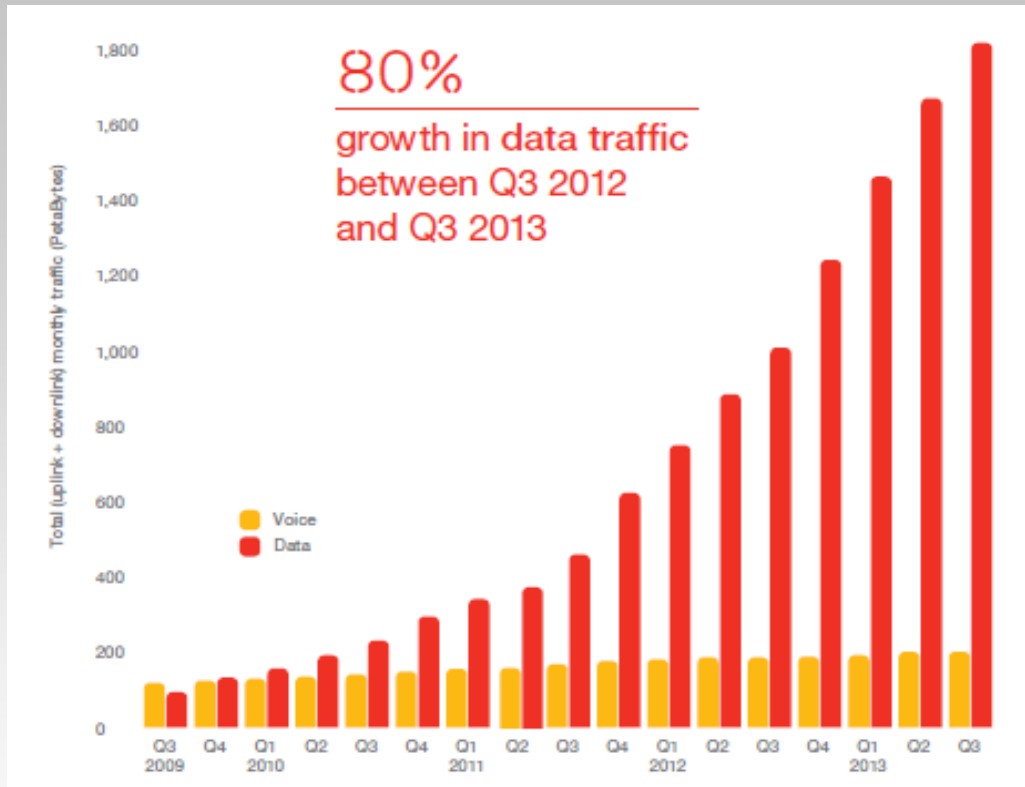

Take away-

- Mobile data is already the several times of capacity than voice in most Operators network
- And data growth will continue exponentially in the years to come

Trend: Application

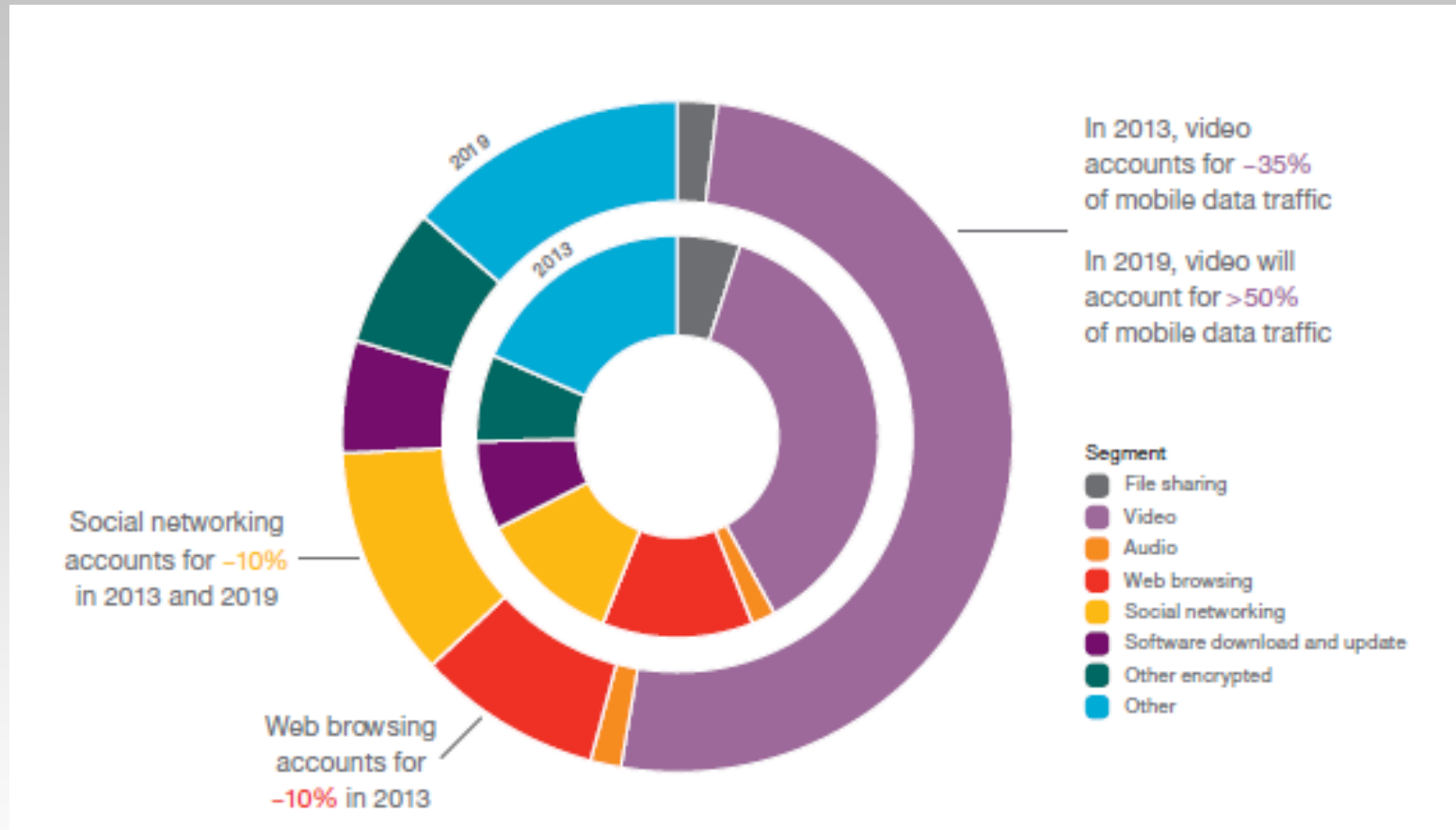

Take away-

- Video is dominant traffic already and will be more dominant in the future

Challenges of building future mobile networks

Some of the challenges include

- Provide mobile subscriptions to the low income segment
- Build network capacity to meet the data traffic explosion while revenue growth is minimal
- Limited spectrum
- Invest in new technology (e.g. HSPA+, LTE) while need to keep legacy network (e.g. GSM, CDMA) for many more years
- Main revenue sources of Operators like voice, SMS is increasingly being commoditized by internet players
- Prediction of huge Machine to Machine subscription which will have low ARPU*.

*ARPU: Average Revenue per User

Latest Smartphone

Bell

HTC Raider™ 4G LTE

Canada's first
LTE superphone

Like 3 likes. Sign Up to see what your friends like.

Buy Now



iPhone 5

- LTE bands 1 (2100), 3 (1800), 4 (AWS), 5 (850), 13 (VzW 700), 17 (AT&T 700), 25 (E1900)
- HSPA bands 850, 900, 1900, 2100
- GSM bands 850, 900, 1800, 1900
- CDMA bands 850, 1900, 2100
- DC-HSDPA



Samsung Galaxy S II LTE

Sveriges första 4G telefon

Samsung Galaxy SII LTE är en ännu snabbare telefon. Den stöder den nya 4G standarden vilket är det snabbaste mobila bredband som finns på marknaden idag. I korthet så är Galaxy SII LTE lite större, något smartare och väldigt mycket snabbare.

Gilla 151

Fler bilder

Se film

TELE2

Nokia Lumia Windows Phone 8



Agenda

- What is mobile communication?
- History and trends
- **Elements in mobile communication systems**
- Basic functionality

Architecture of GSM Network

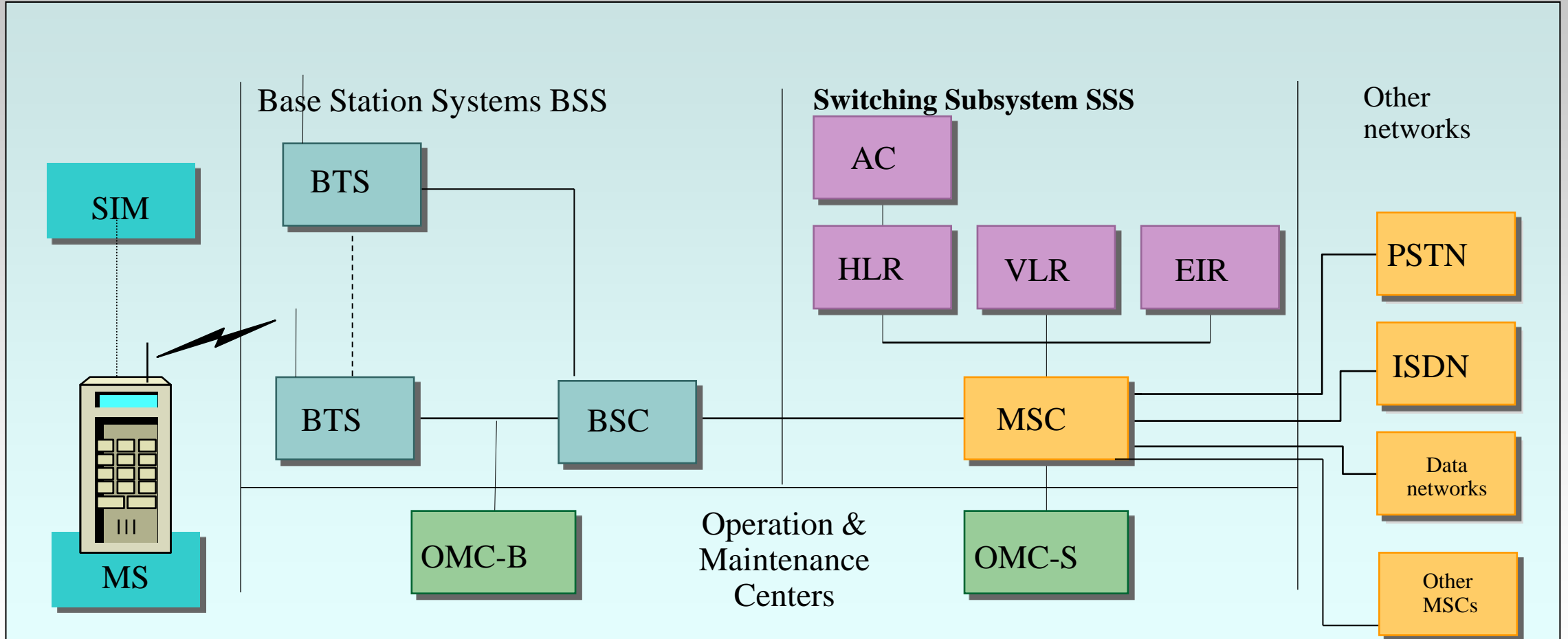

Basic elements in mobile communication systems

SIM – A smart card stores identification (IMSI) of a subscriber, holds Auth. Key that identifies SIM on the mobile network

ME/MU/MS – the mobile device

BTS – Facilitate wireless communication between UE/ME and the network

BSC – Allocates radio channel to ME, several BTS under the control of one BSC

MSC – carries out call switching (ME-ME, ME-phones of other network)

VLR – linked to MSC, temporary DB of subscriber who roamed into a specific MSC

HLR – a central DB of ME

AuC – to authenticate each SIM

EIR – keeps lists of ME which are to be banned or monitored



Basic elements

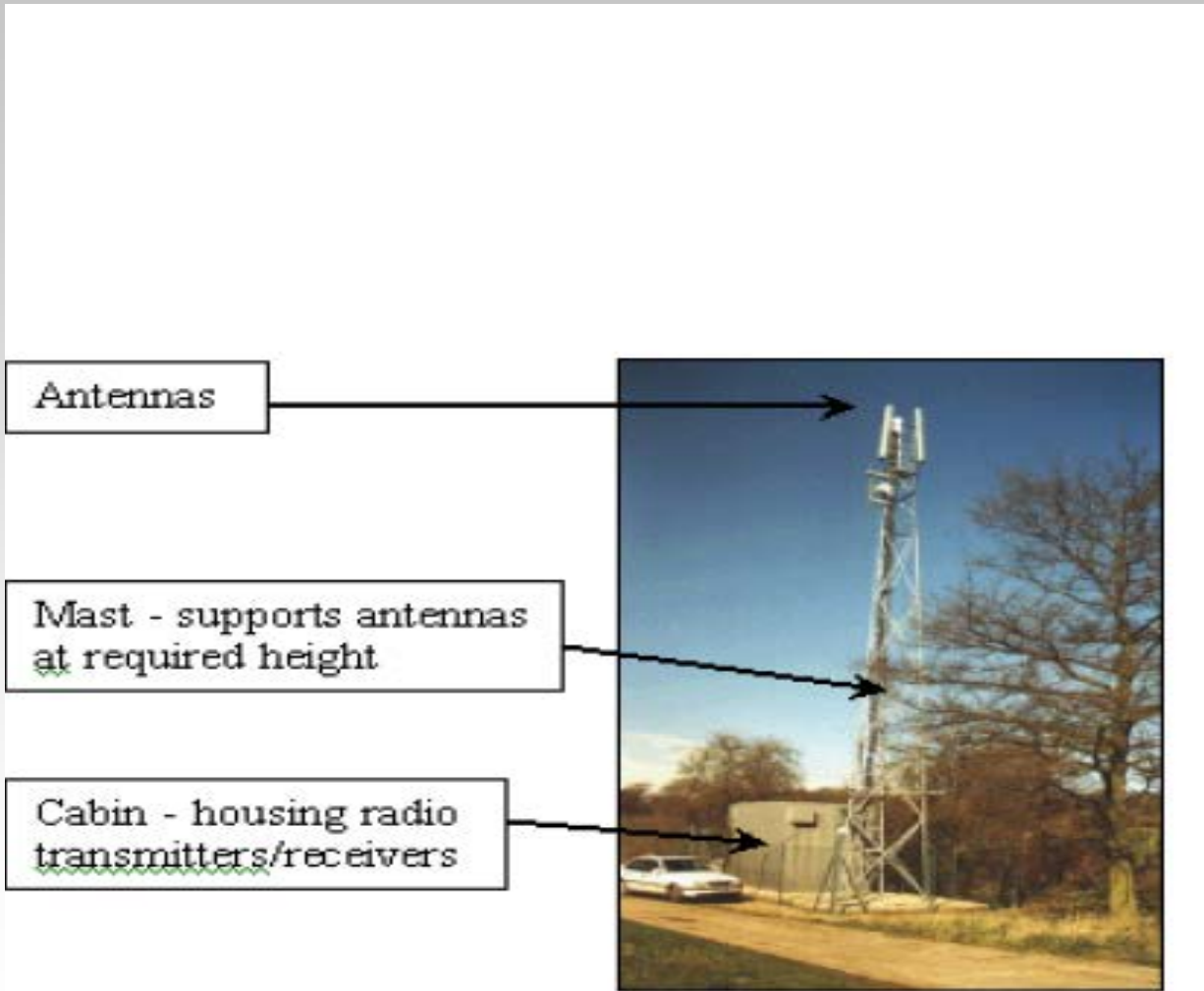

Some concepts in mobile communications

- **Cell** – A limited geographic area covered by a BTS (e.g. max. Cell size of GSM cell 35km, typically several km)
- **Control channel** – Radio channel used for all control info. e.g. call request, call set up etc.
- **Information channel** – Radio channel used for user info. e.g. data or voice
- **Downlink (forward channel)** – communication from BTS till ME
- **Uplink (reverse channel)** – communication from ME till BTS
- **Handover (handoff)** – transferring an ongoing communication from one BTS to another BTS typically due to movement
- **Full duplex/half duplex/simplex** –
 - Both direction simultaneously/ both direction but only one direction at a time/Only one way communication

Basic elements

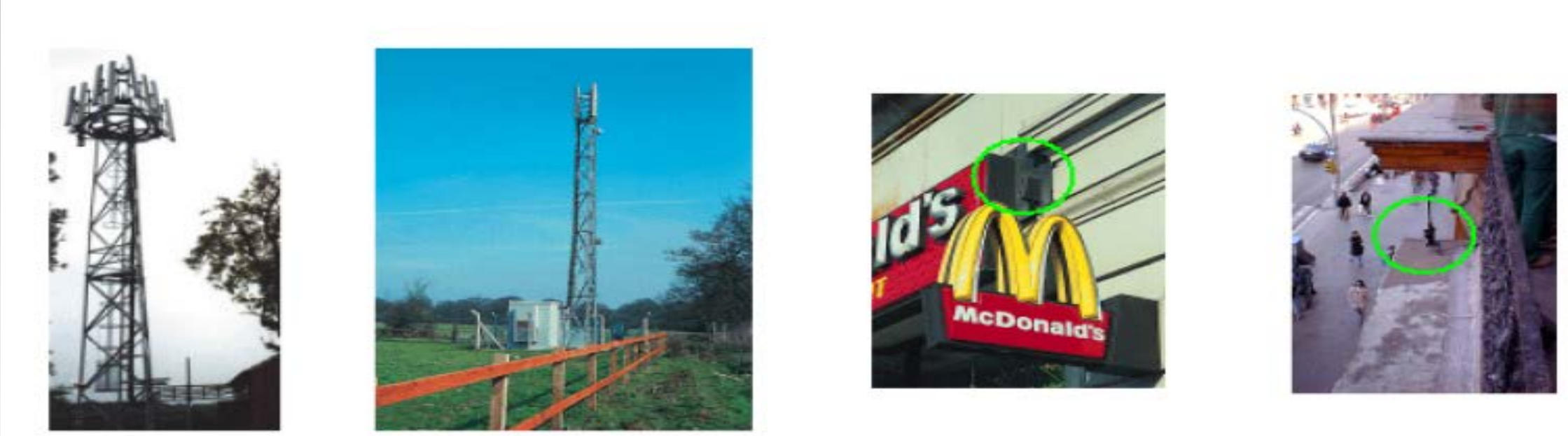

Typical macrocell

Typical microcell

Agenda

- What is mobile communication?
- History and trends
- Elements in mobile communication systems
- **Basic functionality**

Services Offered in GSM

Tele-services

- Mobile telephony
- Emergency calling

Bearer Services

- Data services up to 9.6 Kbps
- Short Message Service (SMS)
- Fax
- Voice mailbox
- Electronic mail

Supplementary services

- Call Waiting
- Call Hold
- Call Barring
- Call Forwarding
- Multi Party Call Conferencing
- CLIP
- CLIR
- CUG

Identification of user and mobile phones

A typical mobile number (MS-ISDN number) follows the numbering plan for telephony (max. 15 digits)

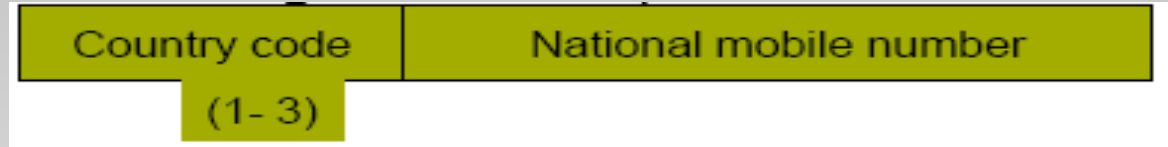

MSISDN = CC + NDC + SN

Where, CC = Country Code, NDC= National Destination Code, SN= Subscriber Number

IMSI used to identify (uniquely) mobile subscription internationally (max. 15 digits)

IMSI = MCC + MNC + MSIN



IMEI used to identify ME

Type `*#06#` to get IMEI

Circuit switching and packet switching

Circuit Switching (CS): In circuit-switched networks, a dedicated path is set up between the two parties. This path remains for the exclusive use of both parties for the duration of the call, and is therefore not available to any other users.

Inefficient mode

E.g. GSM used CS

Packet switching (PS): Packet switching involves dividing the data into packets (or cells or frames) prior to transmission. The length of the packets varies enormously, depending on the technology employed. Added to each packet is the destination address, together with other control information. The packets are then transmitted across the network. This addressing means there is no requirement to set up a pre-established link. To some extent, each individual packet can be viewed as being able to find its own way to its destination.

In a packet-switched network, the resources are shared between many users.

Efficient but of course takes more data field

E.g. from 2.5 G uses PS

Message services

SMS

A text communication service of mobile communication system using standard communication protocols that allow short text messages (typically 160 characters) between mobile devices or between fixed lines and mobile devices.

SMS service is the most successful mobile service commercially

MMS

MMS is a standard way to send multimedia content (e.g. text, audio, video) to and from Phone

Both SMS and MMS are 'store and forward' service

Security functionality

The purpose of security features is to protect users and the network against abuse:

- Verification that the user has a valid subscription
- Verification of the network that the user communicates with a 'real' network entity
- Protection of user's identity against tracking
- Protection against eavesdropping by radio link

Mutual authentication crucial (e.g. In 3G, not in 2G)

User's identity information is stored both in SIM card and in the network

Advanced encryption method is used on radio channel to protect information

Security mechanisms are also used in core network (not only in access network where information is transmitted over the radio)

BUT there is no appropriate location privacy in today's mobile network

Roaming

The continuity of communication services in a location that is different from the home location where the service was registered.

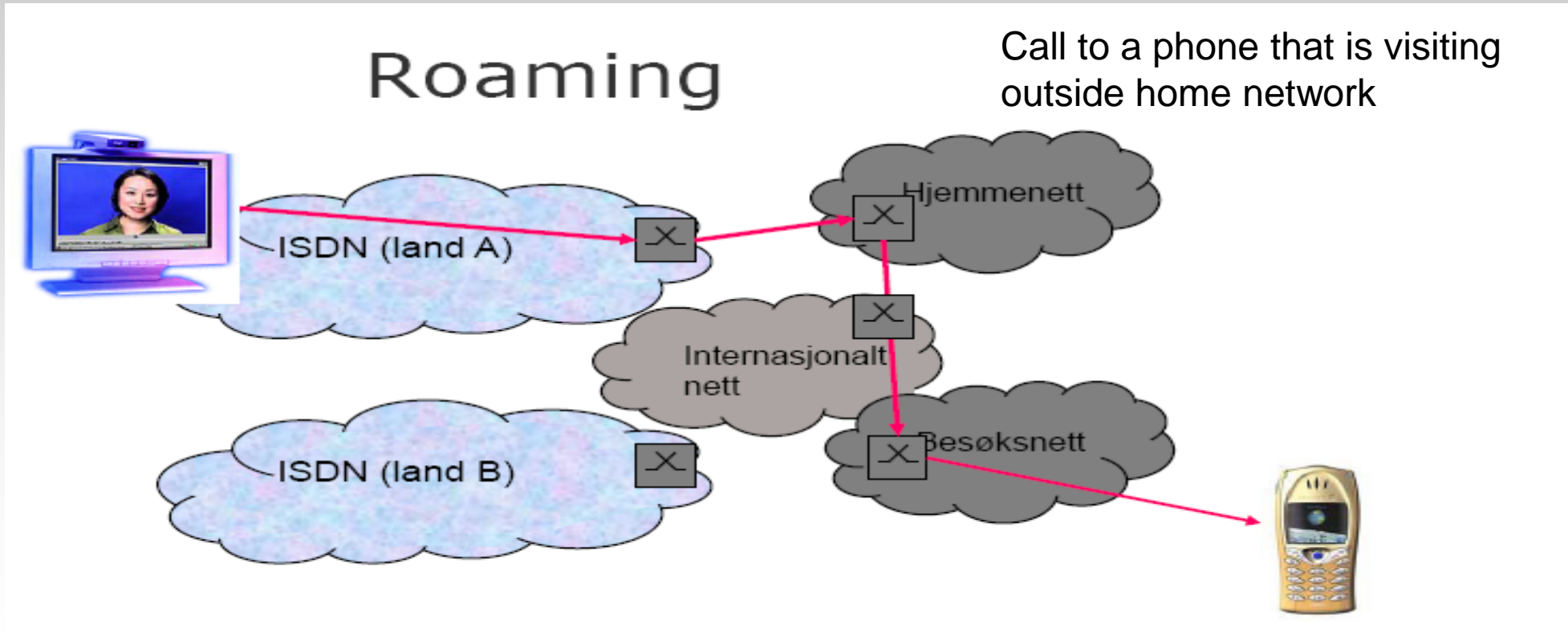

Roaming

Roaming (2)

Mobile to mobile call in a visited network

