



UNIK4230: Mobile Communications

Spring Semester, 2015

Per Hj. Lehne

per-hjalmar.lehne@telenor.com

916 94 909

Network Architecture and Functionality

5 February 2015

Contents

- Network Architecture
- Protocol Stacks
- Basic Network Functionality
- Service Types

Contents

- Network Architecture
- Protocol Stacks
- Basic Network Functionality
- Service Types

Network Architecture Overview (1)

- Main components of a mobile network architecture

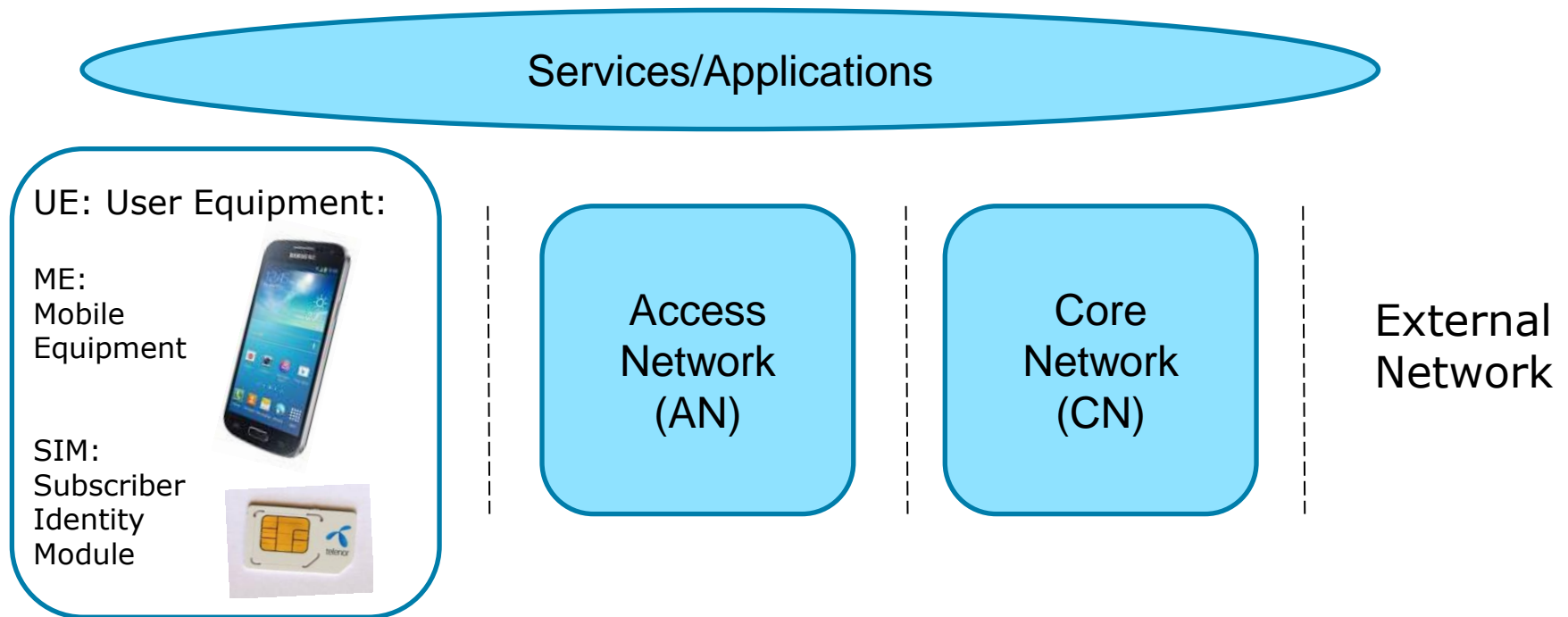

Network Architecture Overview (2)

- **Functionally, the network consists of:**
 - *User equipment (UE)*; User interface, handling radio functions
 - *Access Network (AN)*; Communicates to and from the user equipment. Handles all radio related functionality in the network
 - *Core Network (CN)*; Communication between the access network and other networks. Handles all switching and routing

- **Services and applications are on top of the network**

Network Architecture

- **There are two main network architectures deployed:**
 - The GSM + UMTS architecture
 - The LTE architecture

Architecture of a GSM Network

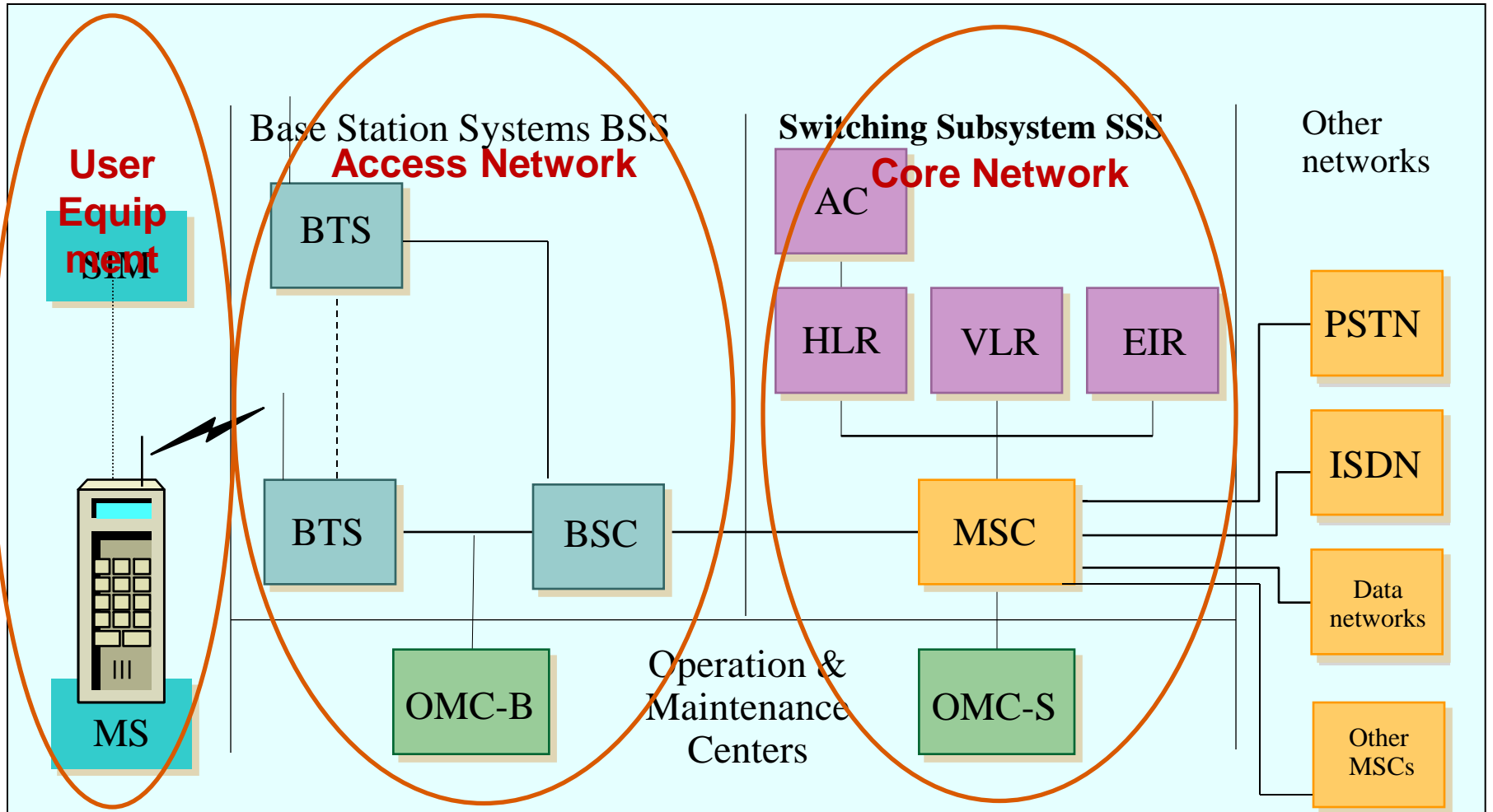

Example access network: UMTS access network

- UTRAN: UMTS Terrestrial Access Network

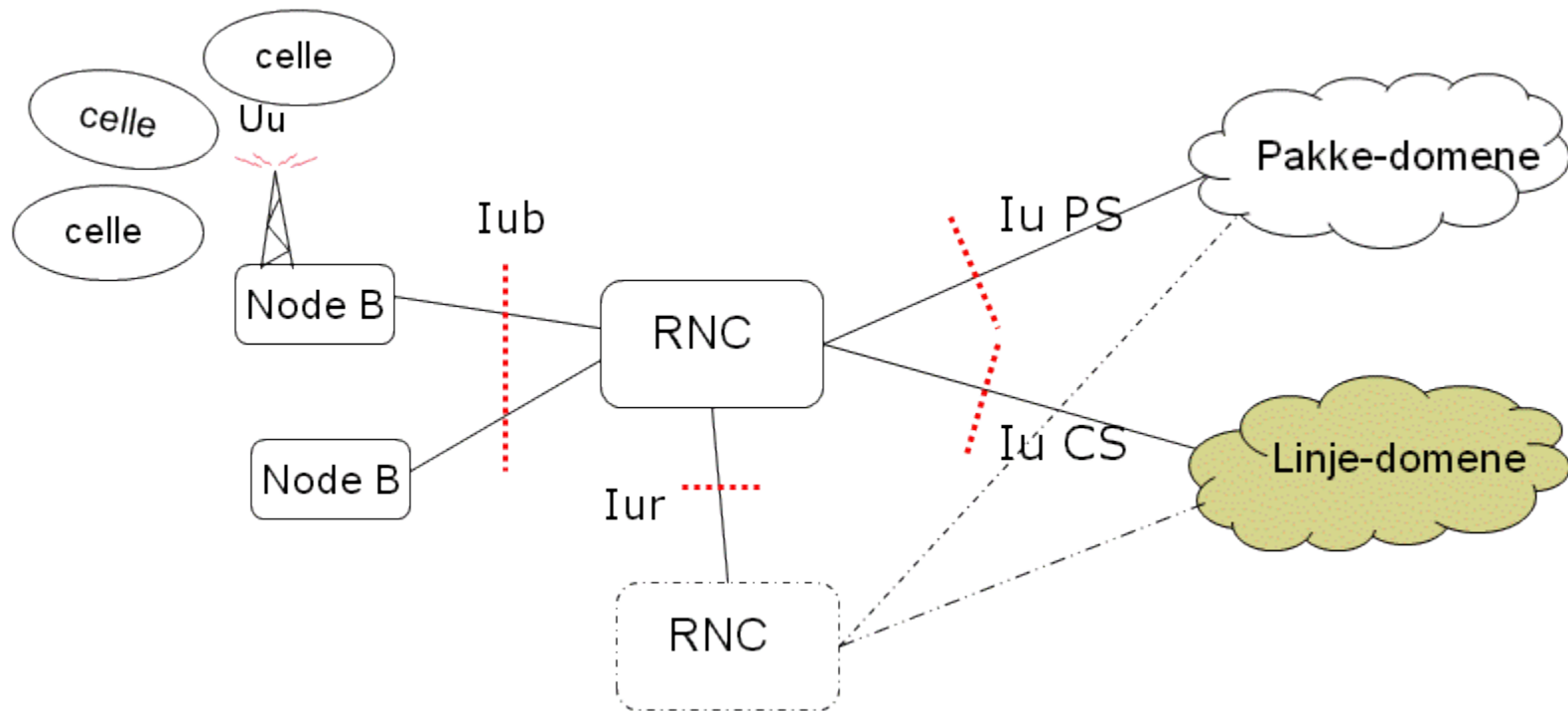

Access network elements in UTRAN

- **Node B:**
 - The base station in UMTS. The coverage area of a Node B is a cell
- **RNC – Radio Network Controller**
 - Controls a number of Node Bs. Owns and controls the radio resources in its domain
- *UTRAN has to handle interfaces both towards a packet-switched (PS-domain) and a circuit switched (CS-domain) part of the core network*

Open interfaces in the Access Network

- *Interfaces between the network elements has to be openly defined so that network elements from different manufacturers can be used together*
- **Four open interfaces are defined in UTRAN:**
 - Uu: Radio interface. Between Node B and user equipment
 - Iub: Interface between Node B and RNC
 - Iur: Interface between different RNCs
 - Iu: Interface between AN og core network (CN). This interface can connect both to a circuit switched (Iu CS) and a packet switched (Iu-PS) part of the CN

Example core network: UMTS core network

- The core network of UMTS and GSM is common:

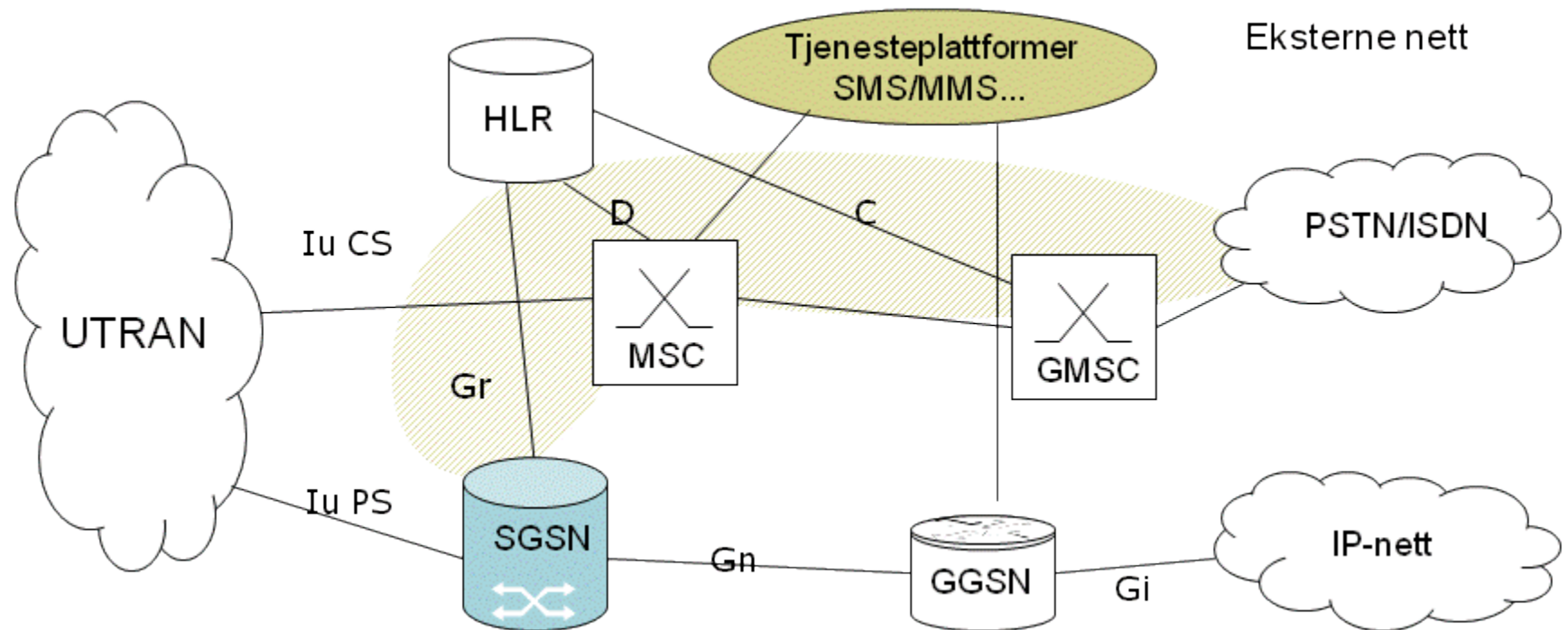

Network elements in the UMTS core network

- **MSC – Mobile Switching Centre**

- Switch in the CS-domain of GSM and UMTS. Contains a copy of the service profile of all users presently located in the coverage area of the MSC (The VLR)

- **GMSC – Gateway MSC**

- Handles all traffic to and from GSM/UMTS and external CS networks like PSTN, ISDN and other mobile networks (PLMNs)

- **HLR – Home Location Register**

- Data base contain the master copy of the user profile of the operator's subscribers. There is only one logical HLR per network. It contains information like allowed services and roaming information

- **SGSN – Serving GPRS Support Node og GGSN – Gateway GPRS Support Node**

- Has a similar functionality as the MSC/GMSC for the Packet-Switched (PS-) domain of the network. GGSN handles all connections to external IP-networks.

Network Architecture of LTE

- Comparing UMTS and LTE:
 - RNC functionality is moved to the eNodeB
 - No CS-domain, only PS-domain
- Reduces latency and increases speed
- Reduces complexity

UMTS Architecture

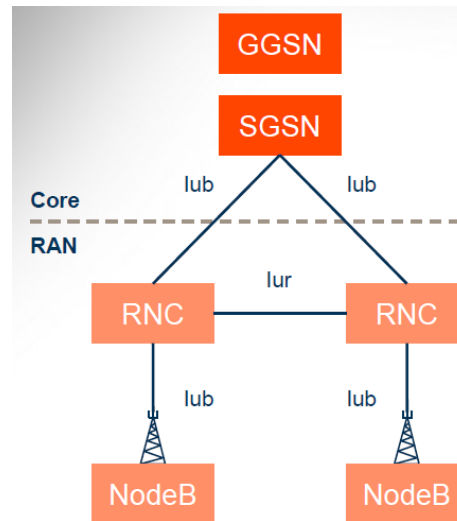

RNC
Ciphering
Radio Link Control
Radio Resource Management
Etc.

NodeB
Link Adaptation
Scheduling
Physical Layer
Etc.

LTE Architecture

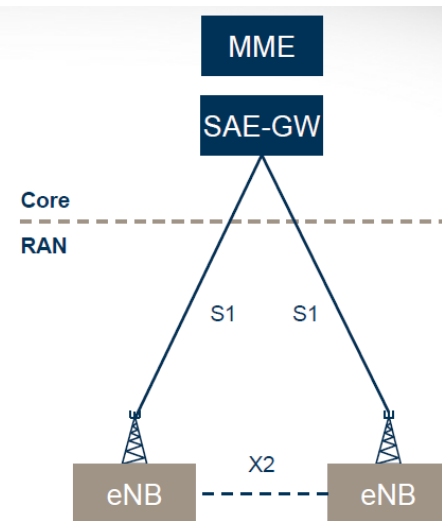

eNodeB
Ciphering
Radio Link Control
Radio Resource Management
Link Adaptation
Scheduling
Physical Layer
Etc.

Network Architecture of LTE (2)

EPS: Evolved Packet System (LTE + SAE)
SAE: System Architecture Evolution
EPC: Evolved Packet Core

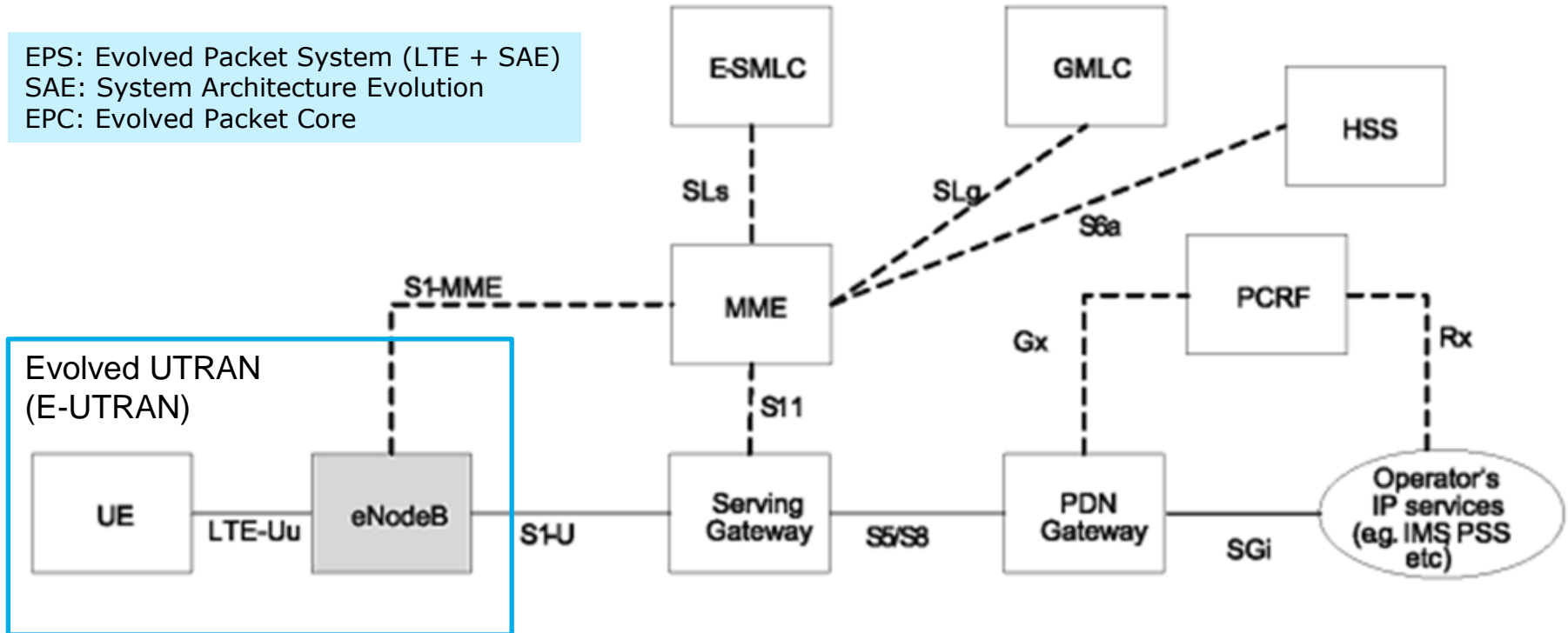

Figure 2.1: The EPS network elements.

PDN Gateway (P-GW)

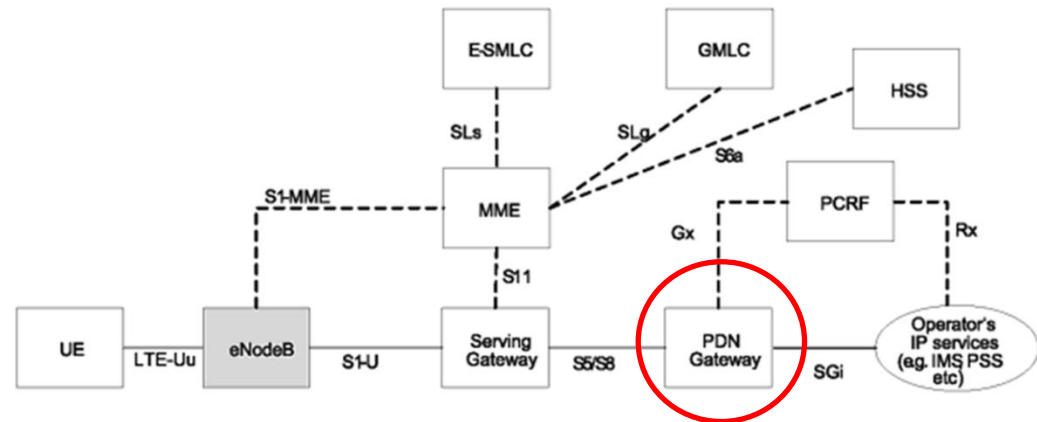

Figure 2.1: The EPS network elements.

- IP address allocation for UE
- QoS enforcement
 - Filtering of DL IP packets to different QoS-based bearers
- Flow based charging
- Mobility anchor for non-3GPP technologies

Serving Gateway (S-GW)

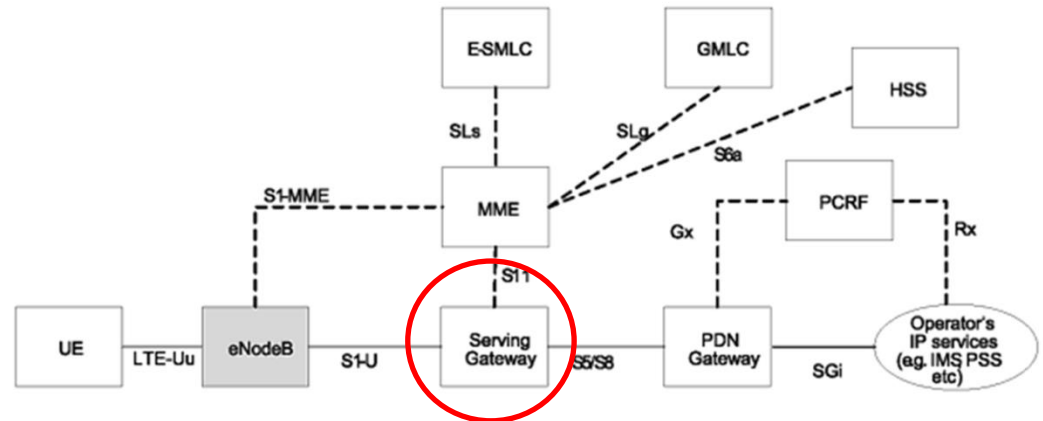

Figure 2.1: The EPS network elements.

- All IP packets are transferred through the S-GW
- Local mobility anchor (when UEs move between eNBs)
- Retains information about bearers when the UE is in idle mode
- Temporarily buffers DL data while bearers to a UE are re-established
- Mobility anchor for interworking with other 3GPP technologies

Mobility Management Entity (MME)

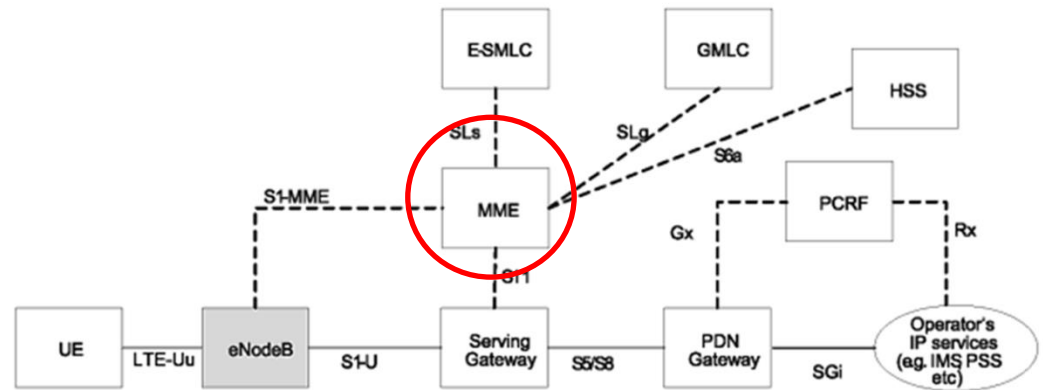

Figure 2.1: The EPS network elements.

- Control node processing the signalling between the UE and the CN
- Bearer management functions
 - Establishment, maintenance, and release of bearers
- Connection management functions
 - Establishment of connection and security between the network and the UE
- Inter-working functions
 - E.g. Handing over voice calls to legacy networks
- Creates an UE context when an UE is turned on and attaches to the network (S-TMSI, downloads subscription data from HSS).

Evolved Serving Mobile Location Centre (E-SMLC)

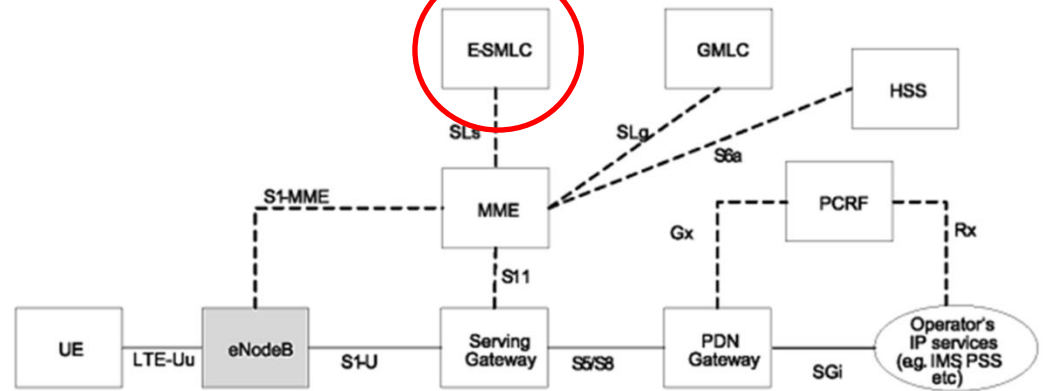

Figure 2.1: The EPS network elements.

- Overall coordination and scheduling of resources to estimate UE location and speed.
- Calculates the final location and speed estimates, and the accuracy of these, based on the estimates it receives.

Policy Control and Charging Rules Function (PCRF)

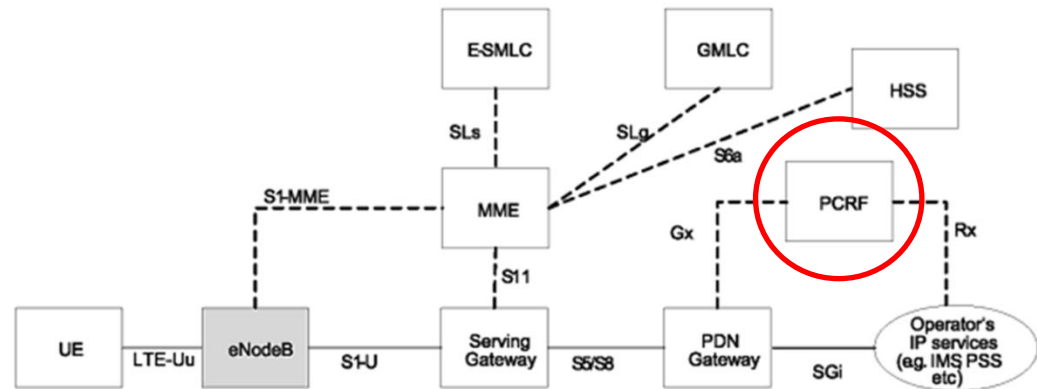

Figure 2.1: The EPS network elements.

- Policy control decision making
- Control of the flow based charging functionalities in the Policy Control Enforcement Function (PCEF), which resides in the P-GW.
 - The PCRF provides the QoS authorization (class and bit rate) that decides how a certain data flow will be treated in the PCEF.
 1. Ensures that this is in accordance with the user's subscription profile

Home Subscriber Server (HSS)

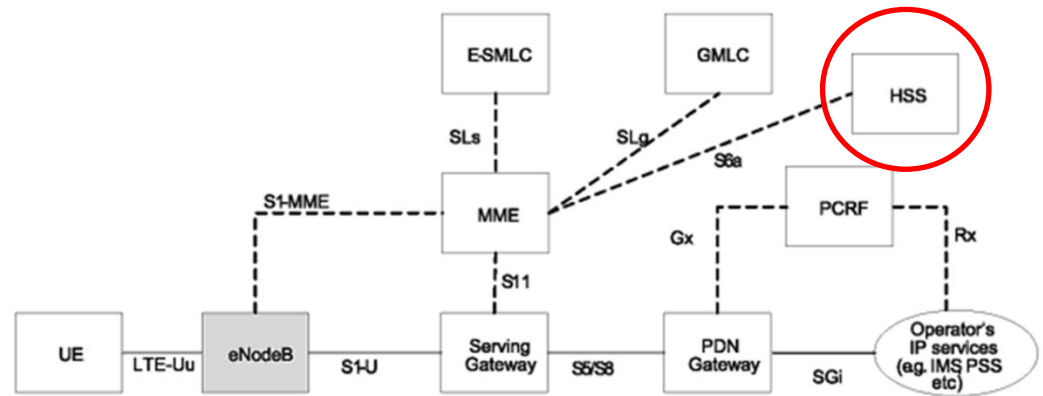

Figure 2.1: The EPS network elements.

- Contains the SAE subscription data
 - Subscribed QoS profile
 - Access restrictions for roaming (if any)
 - Which PDNs the user can connect to
 - Identity of the MME the user is currently attached to
 - May include the Authentication Center which generates the vectors for authentication and security keys.

Summary network architecture

- The mobile network is functionally divided into User Equipment (UE), Access Network (AN) and Core network (CN):
 - The UE is the interface towards the user and handles radio functionality
 - The AN communicates to/from the Ues and handles all radio related functionality in the network
 - The CN handles communication between the AN and external networks, including all switching and routing
- The AN in UMTS is called UTRAN and consists of NodeBs (the base stations)
- The core network of UMTS is the same as for GSM and consists of a circuit switched (CS) and packet switched (PS) domain
- The LTE network is called EPS and consists of the E-UTRAN AN and the EPC CN
- The LTE network is only packet switched
- There has to be openly defined interfaces between network elements to allow equipment from different manufacturers to be connected to each other

Contents

- Network Architecture
- **Protocol Stacks**
- Basic Network Functionality
- Service Types

Communications Protocols

- A common abstraction to handle the complexity in communications networks is a layered approach. Protocols handle functionality on each layer
- This makes functionality in the layers below transparent for the layers above. The design and maintenance become easier because the interface between each layer is well-defined
- A common model is the Open Systems Interconnection (OSI) protocol stack which defines 7 layers

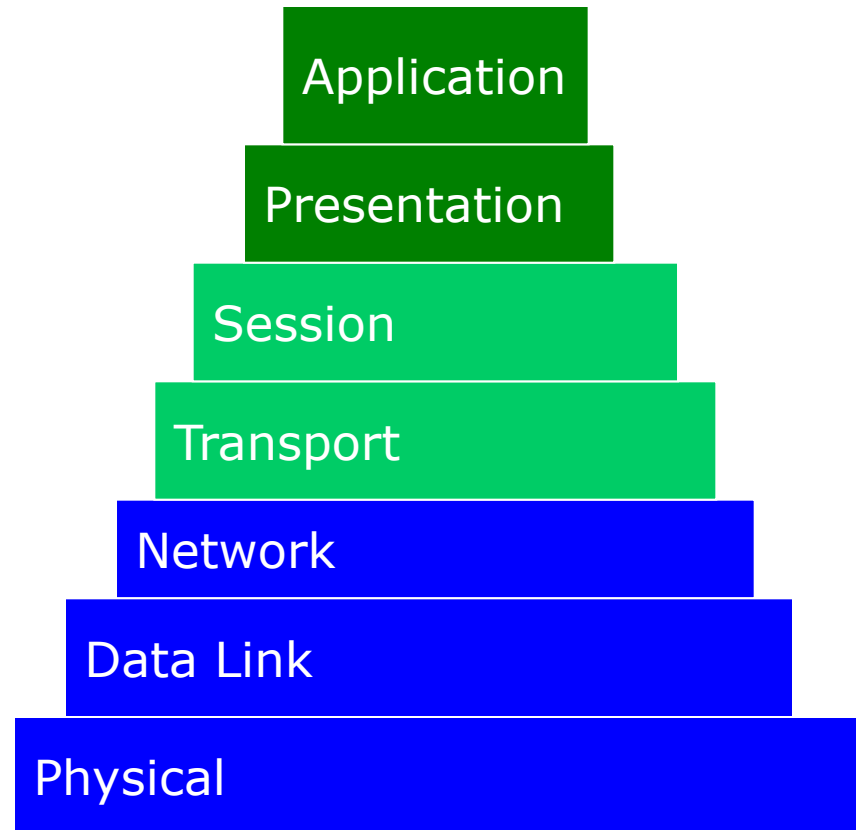

The OSI model

- Physical Layer:
 - Transmission of bits. Mechanical and electrical levels. Modulation
- Data Link Layer:
 - Reliable transfer of blocks and frames of data with required synchronization, error control and flow control. Example: Ethernet
- Network Layer:
 - Independence of transmission and switching/routing. Establishes, maintains and terminates links. Example: IP
- Transport Layer:
 - Ensures reliable and transparent transfer of data between end points. Offers end-to-end error control and flow control. Example: TCP

The OSI model (2)

- Session Layer:
 - Offers control structures for communication between applications. Establishes, handles and terminates sessions
- Presentation Layer:
 - Offers independence to the application processes related to different data representations. Syntax, coding etc.
- Application Layer:
 - Offers access for users, and offers distributed information services. Communication between applications, e.g. http

The protocol stack in Mobile networks (GSM/GPRS/UMTS)

- A modified protocol stack is used in mobile systems to handle special functions compared to other computer networks
- The protocol stack and network elements for UMTS:

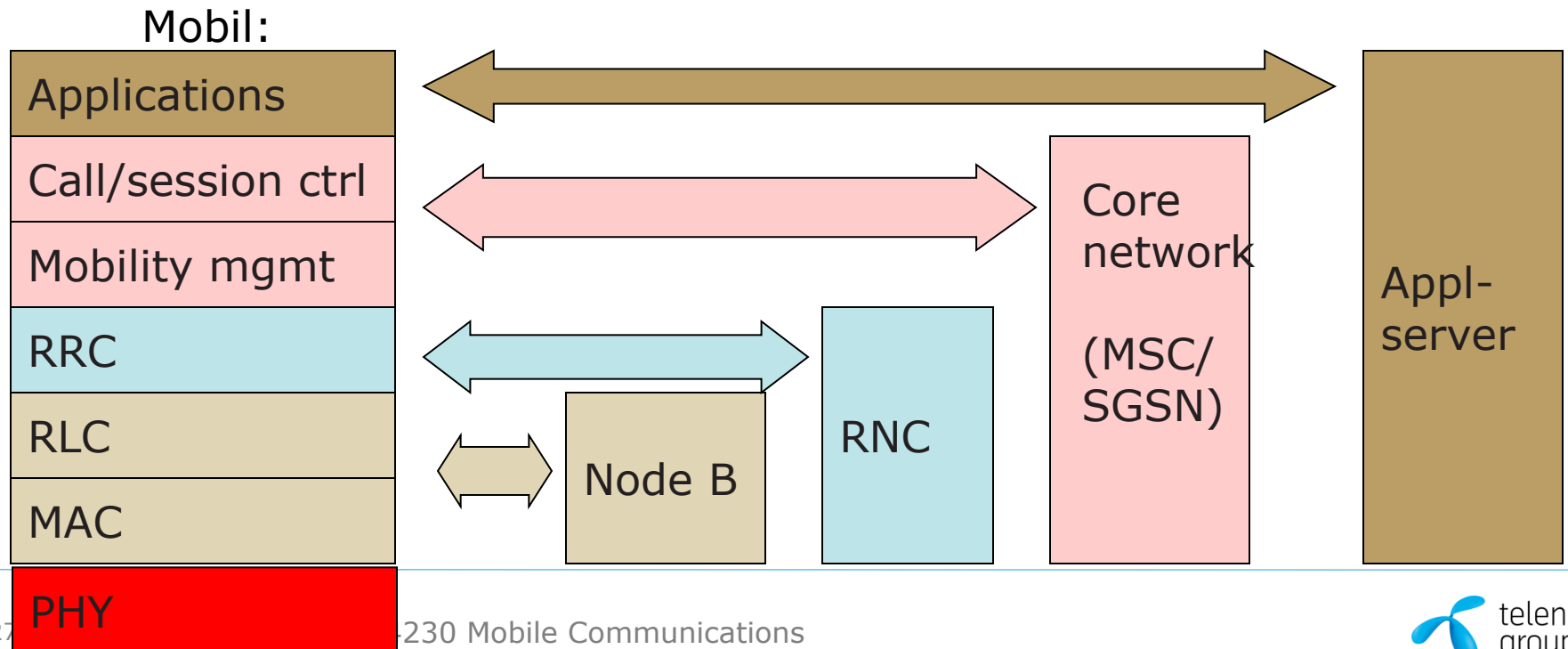

The protocol stack in Mobile networks (2)

- Layer 1, Physical layer:
 - Modulation, coding, multiplexing
- Layer 2, Data Link Layer:
 - Divided in two sub-layers:
 - MAC – Medium Access Control. Handles the access to control channels and is required to establish a call or control who and how many who is accessing the network
 - RLC – Radio Link Control. Handles the radio link, including power control and link quality measurements (signal level and interference)

The protokol stack in Mobile networks (3)

- Layer 3, Network Layer.
 - Divided in three sub-layers:
 - RRC – Radio Resource Control. Sets up, maintains and terminates the use of radio and fixed line resources, including handover.
 - MM - Mobility Management. Handles location updates, registering, security and authentication.
 - Call / Session Control. Controls call and sessions set ups
- Layer 4 and above is not different from other communication networks

Radio protocols

- Layer 1 and 2 makes up the radio protocols:
 - Physical Layer
 - MAC Layer
 - RLC Layer

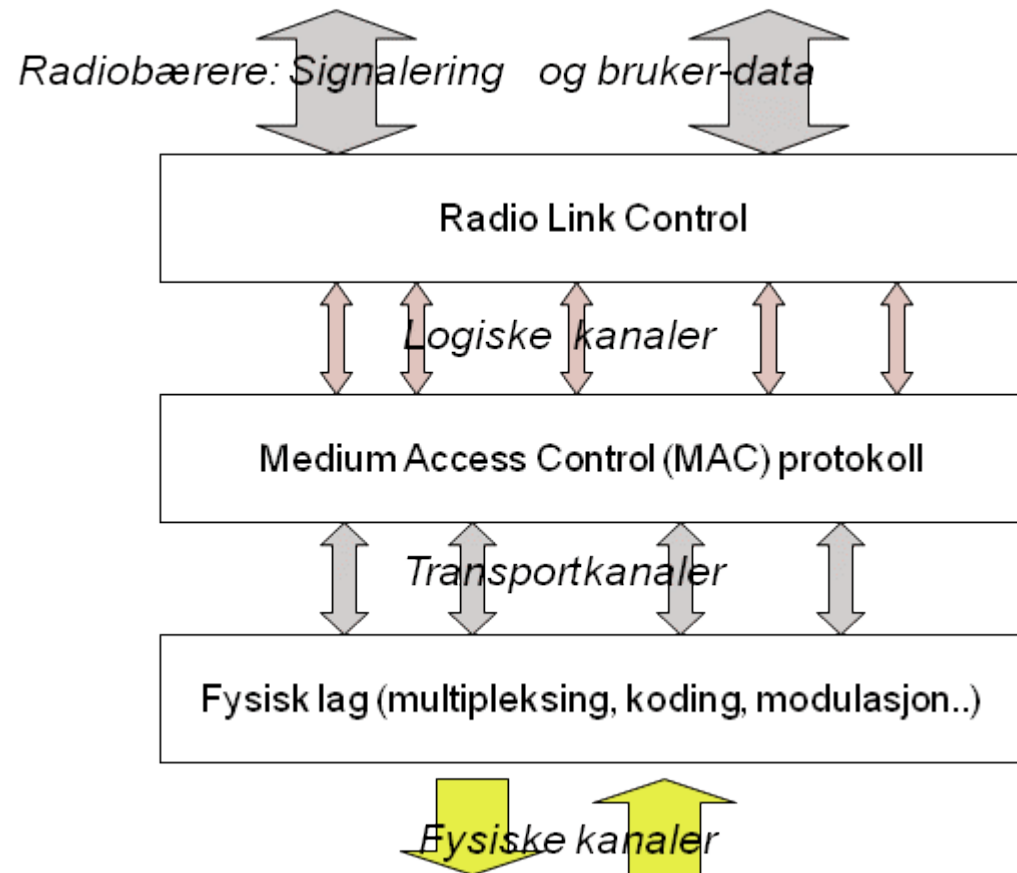

Radio protocols (2)

- Radio bearers are available for the layers above the radio protocols
- Two main types:
 - Signalling bearers:
 - All exchange of signalling information related to radio resource control and higher protocol layers
 - Data bearers:
 - To transfer the information itself (user data)

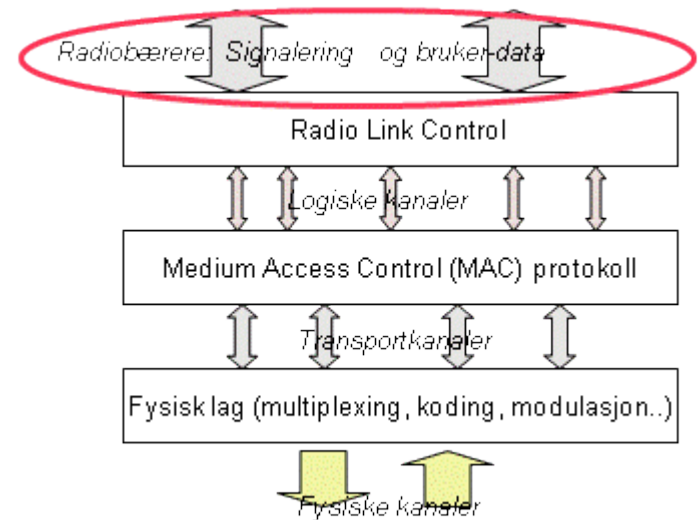

Radio protocols (3)

- Layer 2 realises the radio bearers on different logical channels:
- Control Channels in UMTS:
 - BCCH: Broadcast Control Channel (DL)
 - PCCH: Paging Control Channel (DL)
 - DCCH: Dedicated Control Channel (UL/DL)
 - CCCH: Common Control Channel (UL/DL)
- Traffic-Channels in UMTS:
 - DTCH: Dedicated Traffic Channel (UL/DL)
 - CTCH: Common Traffic Channel (DL)

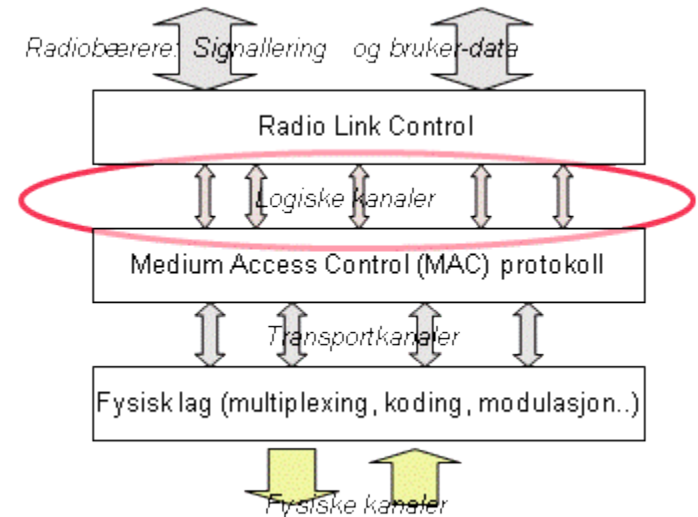

Radio protocols (4)

- The Logical Channels are mapped to Transport Channels
- Transport Channels in UMTS:
 - BCH : Broadcast Channel – System information sent to all mobiles in the cell
 - RACH: Random Access Channel – Channel used by the mobiles to send an initial message to establish contact with the network
 - FACH: Forward Access Channel – Addressed information to mobiles in the cell (e.g. response to RACH messages)
 - PCH: Paging Channel – To search for mobiles in one or more cells (e.g. when a call to a mobile must be established)
 - DCH : Dedicated Channel – Channel for sending data between a selected mobile and the network

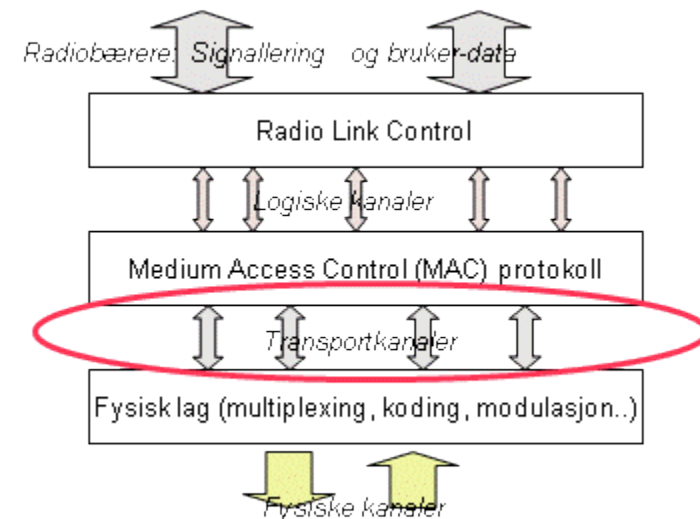

Radio protocols (5)

- Physical Channels
 - All Transport Channels have a corresponding Physical Channel with a few exceptions:
 - FACH og PCH use the same Physical Channel
 - DCH uses two different Physical Channels. One for transfer of the data itself and one Control Channel to handle e.g. variations in the bit rate.
- There are also some special Physical Channels for the access itself, like pilot signals, synchronization information etc.

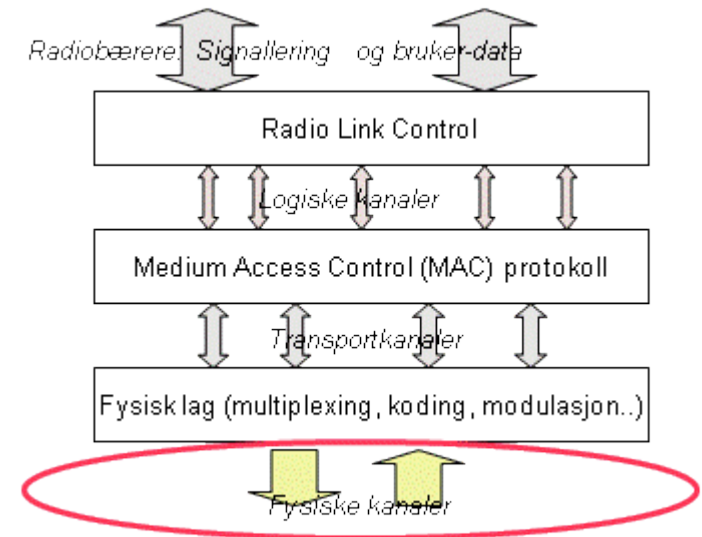

LTE Downlink Physical Data Channels

- Physical Broadcast Channel (PBCH)
 - System information
- Physical Downlink Shared Channel (PDSCH)
 - The main data bearing DL channel in LTE
- Physical Multicast Channel (PMCH)

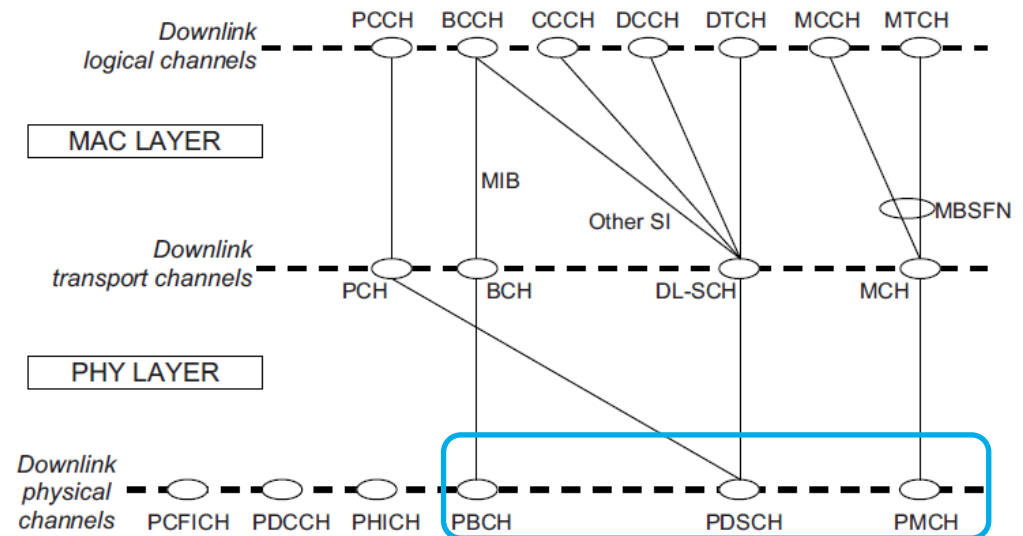

LTE Downlink Control Channels

- Physical Layer Signalling to support the MAC layer
- Physical Control Format Indicator Channel (PCFICH)
 - Control Format Indicator (CFI) – # OFDM symbols for control channel info in each subframe
- Physical Hybrid ARQ (HARQ) Indicator Channel (PHICH)
 - HARQ Acknowledge information, related to the uplink data
- Physical Downlink Control Channel (PDCCH)
 - Downlink Control Information (DCI): Resource assignments and other control information for a UE or group of UEs

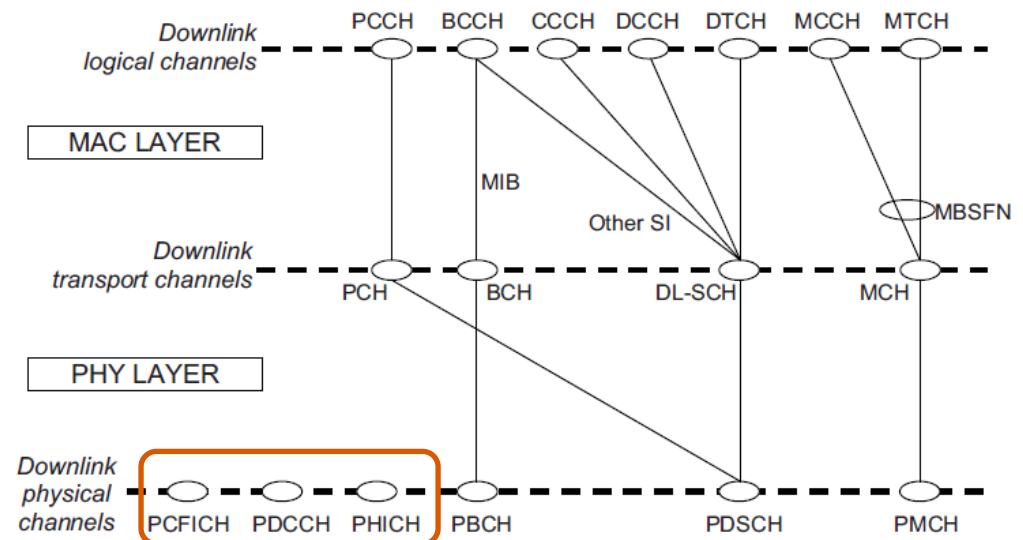

LTE Uplink Physical Channels

- Physical layer transmissions of LTE uplink comprise of three physical channels and two signals
- PUSCH –Physical Uplink Shared CHannel
- PUCCH –Physical Uplink Control Channel
- PRACH –Physical Random Access CHannel

- DM-RS –DeModulation Reference Signal
- SRS –Sounding Reference Signal

LTE Uplink Physical Channel structure

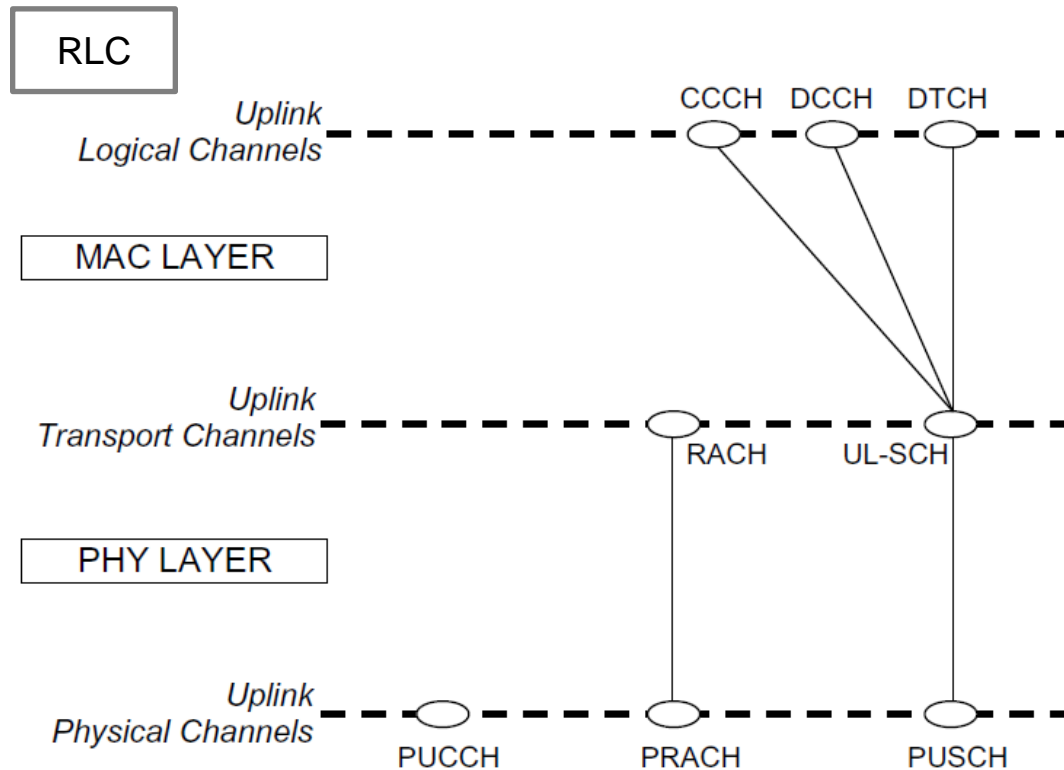

- MAC layer provides a data transfer service for the RLC layer through logical channels
- Data from the MAC layer is exchanged with the physical layer through transport channels

Summary Protocol Stacks

- The Protocol Stack in a Mobile Network are modified compared to other communications networks, because there is a need for some special functions:
 - Layer 2, Data Link Layer is divided in two sub-layers:
 - MAC – Medium Access Control. Handles the access to control channels and is required to establish a call or control who and how many who is accessing the network
 - RLC – Radio Link Control. Handles the radio link, including power control and link quality measurements (signal level and interference)
 - Layer 3, Network Layer is divided in three sub-layers:
 - RRC – Radio Resource Control. Sets up, maintains and terminates the use of radio and fixed line resources, including handover.
 - MM - Mobility Management. Handles location updates, registering, security and authentication.
 - Call / Session Control. Controls call and sessions set ups
- The Radio Protocols are protocols on Layer 1 and 2; Physical and Data Link Layers
 - The Radio Bearers are channels which are made available to the layers above layer 2 and are two main types:
 - Signalling bearers
 - Data bearers

Contents

- Network Architecture
- Protocol Stacks
- **Basic Network Functionality**
- Service Types

Some basic network functions

- Network choice
- Location update
- Call/session setup:
 - Circuit switched
 - Packet switched
- Handover

Network choice

- In GSM/UMTS the following procedure is used:
 - The last used network is stored in the SIM
 - If a cell meeting the criteria is available/within coverage, the mobile does not look for alternatives
 - Exception: If national roaming is possible, the mobile is periodically looking for the home network and attaches to this when available
 - If the last used network is not available, the mobile will search for alternative networks
 - The mobile can be set to choose network automatically or manually

Location area / Routing area

- **In UMTS the definition is as follows:**

- Location area (LA) is the area in which the network will search for a registered mobile (which is not currently active) – for circuit switched services
- Routing area (RA) for packet switched services

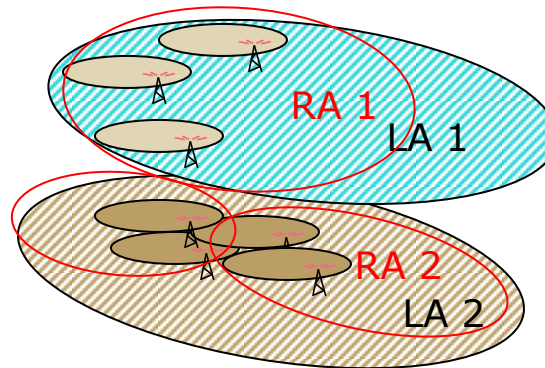

- *The relationship between LA and RA is dependent on the network realization. They are usually identical.*
- *LA and RA consist of a number of cells which can be reached from a specific MSC or SGSN*
- *LA and RA information for each mobile (IMSI) is stored in the Home Location Register (HLR) in the home network*
- *The mobile is responsible for updating the information*

Location update

- Location update is performed when:
 - The mobile is attaching to a cell and discovers that its LAI has changed
 - The mobile is 'on' but in idle mode and a certain time has elapsed since the last update (periodic location update)
- IMSI detach/attach:
 - An additional function where the mobile sends a message that it is turned off or on (in the same LA). Saves radio resources and faster response on incoming calls
- Periodic detach
 - A network function which assumes that the mobile is turned off, if a periodic location update is missed and no other activity has been detected

Location update (2) Procedure

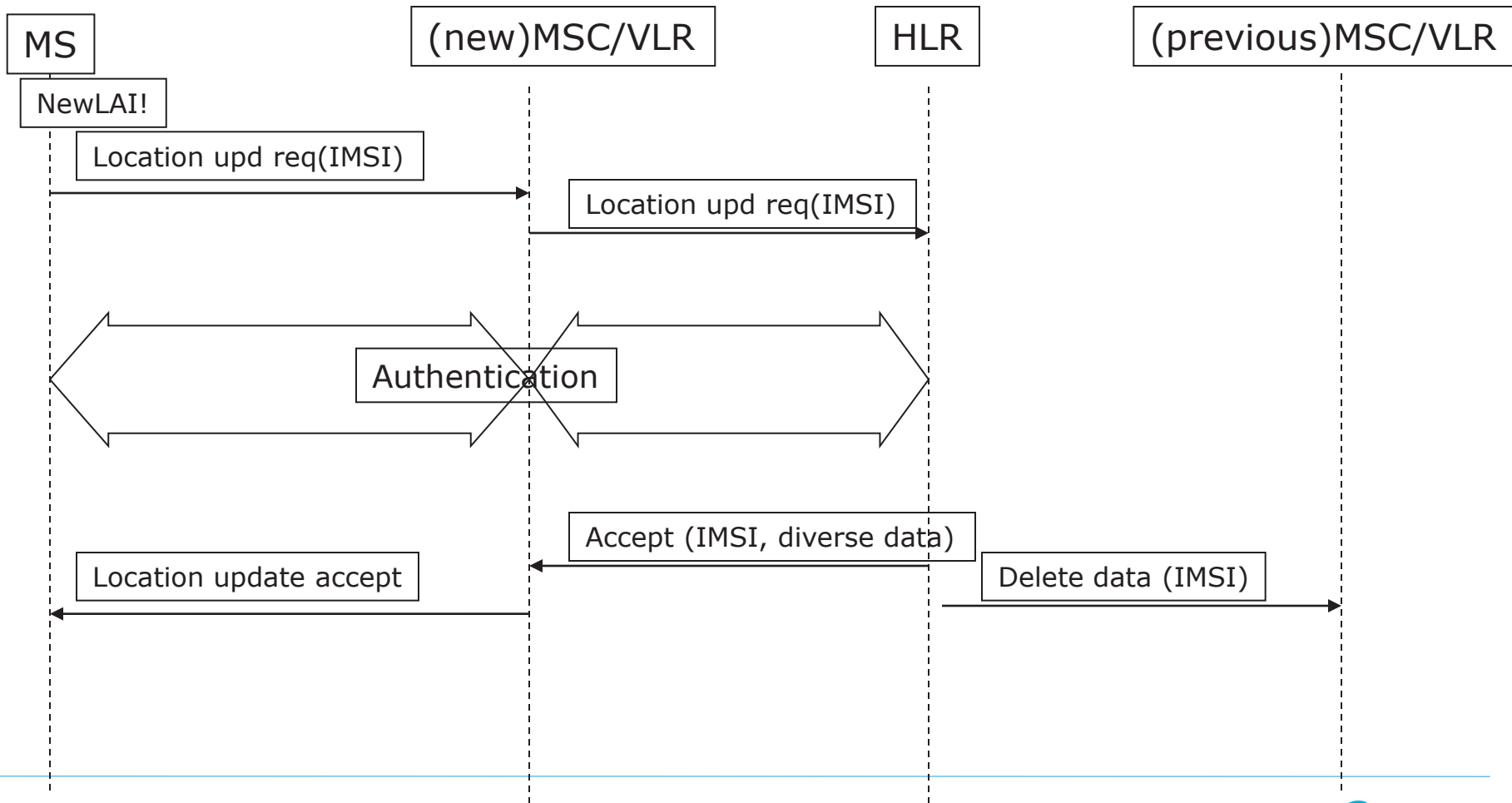

Call setup, circuit switched connection

Procedure for mobile originated call

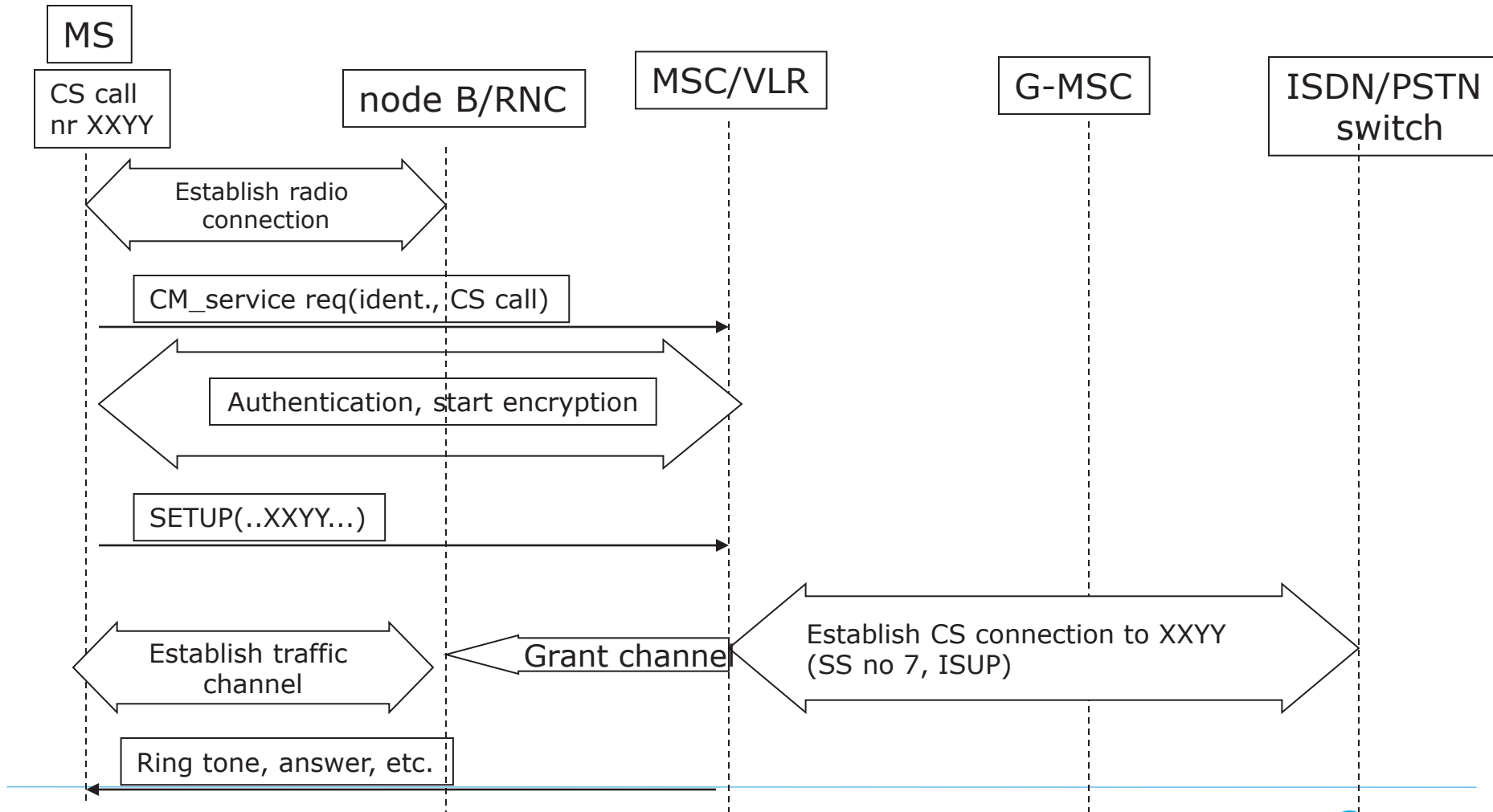

Packet data setup session, Procedure for mobile initiated PS session

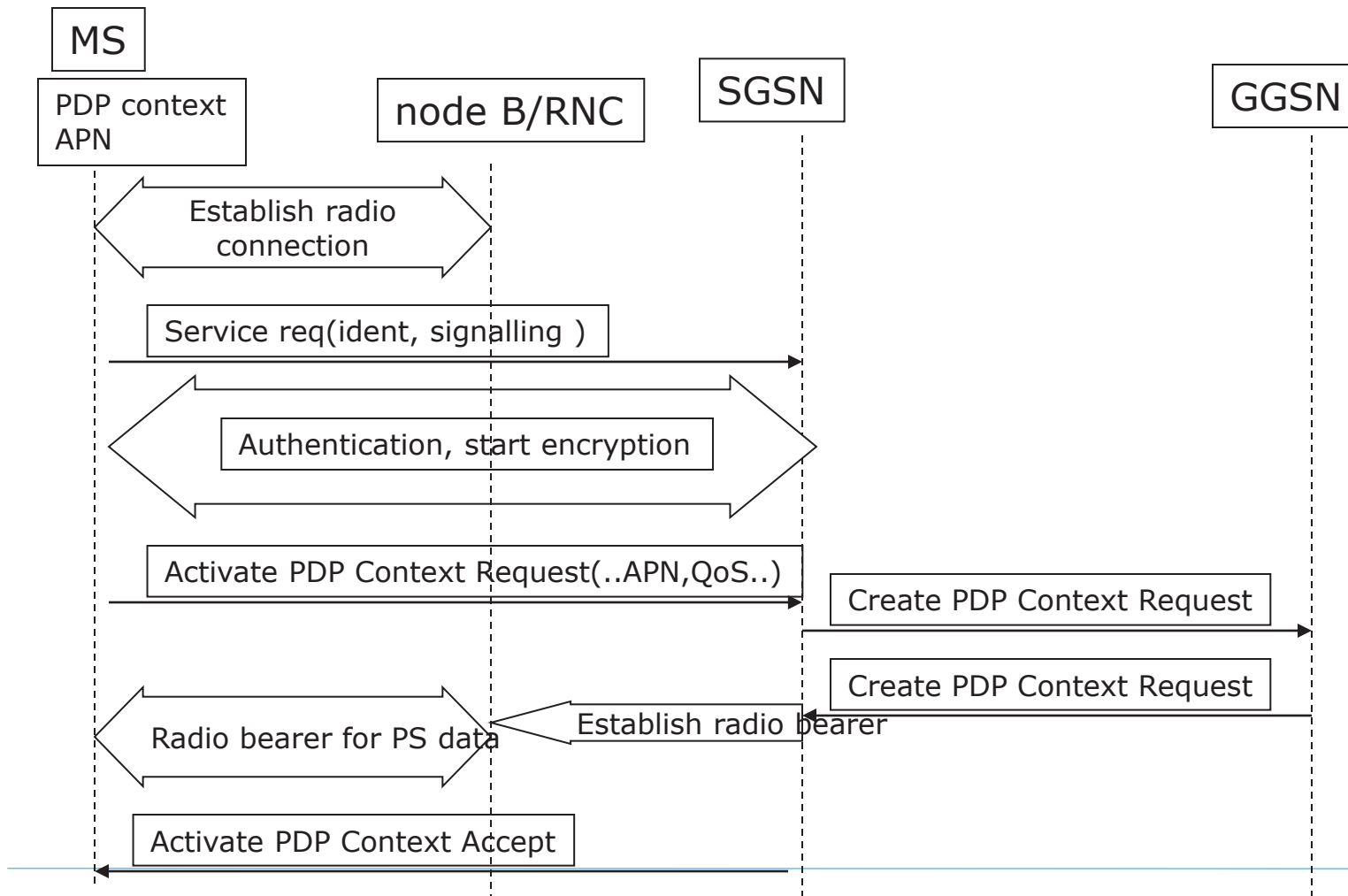

Handover

- Transfer of an active communication session/call from one cell to another (active CS connection eller PS session)
- *Different types of handover:*
 - Between cells on same Node B
 - Between cells on different Node Bs belonging to the same RNC
 - Between cells on different Node Bs belonging to different RNCs, but same MSC/SGSN
 - Between cells on different Node Bs, RNCs and MSC/SGSNs
 - Between cells using different radio technology, e.g. UMTS and GSM

Handover example: Different RNC and SGSN

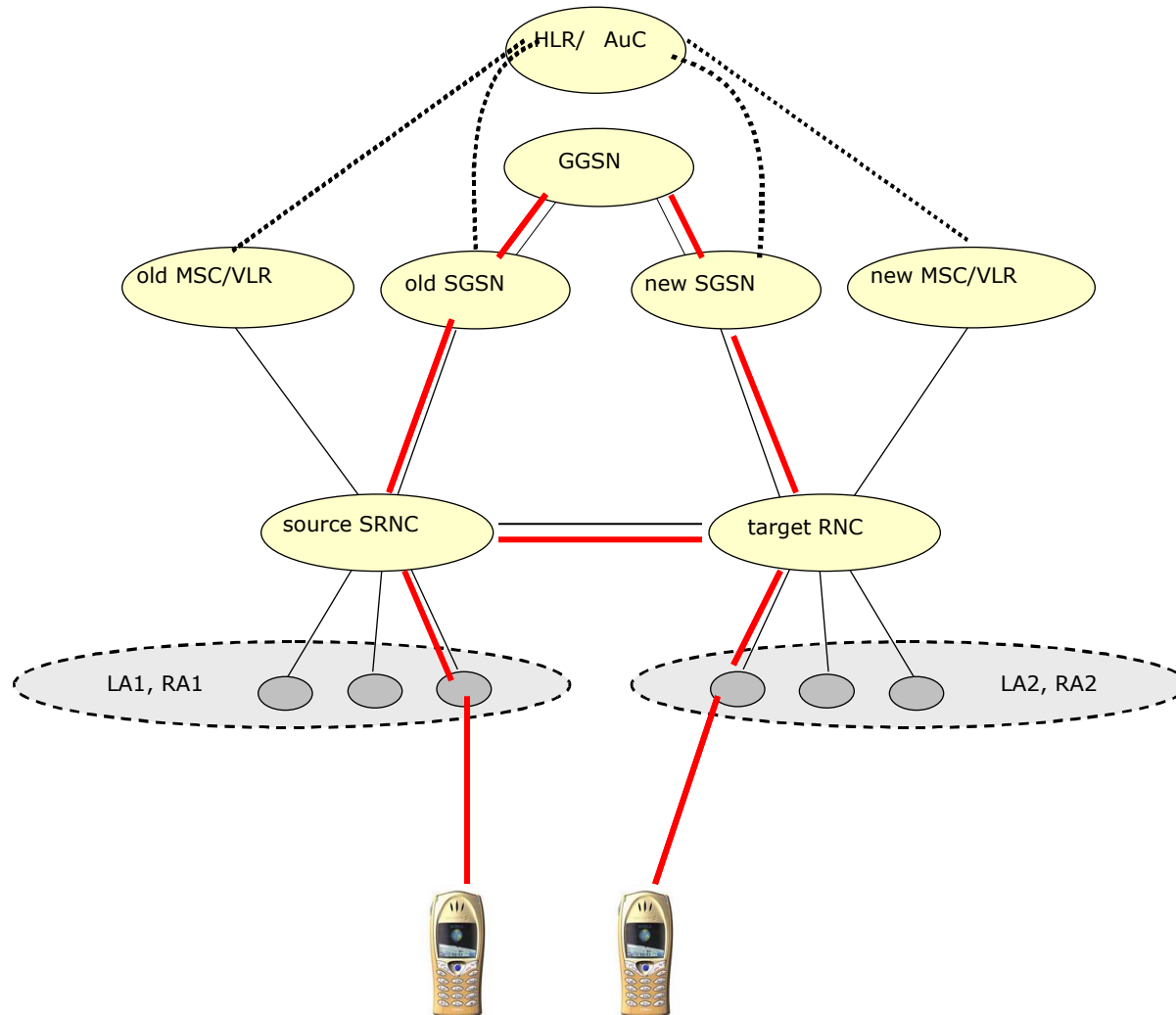

Summary, basic network functionality

- **Network choice:** In GSM and UMTS the mobile will use the network stored in the SIM as long as it is available. Network choice can be automatic or manual
- **Location update** provides information to the network about the Location Area (LA) the mobile is in. It is performed when:
 - The mobile is attaching to a cell from a different LA
 - A certain time has elapsed since the last update
- **Call/session setup** is done according to special procedures which handles authentication and security
 - It is different between CS and PS setups, and the type of external network
- **Handover** is the transfer of an active call/session from one cell to another

Innhold

- Network Architecture
- Protocol Stacks
- Basic Network Functionality
- **Service Types**

Service classes

Applications and services can be defined in four traffic classes

Service class characteristics:

<i>Traffic class</i>	<i>Conversation</i>	<i>Streaming</i>	<i>Interactive</i>	<i>Background</i>
<i>Fundamental characteristics</i>	Maintains timing between frames and bits Tight requirements for low latency (delay)	Keeps timing between frames and bits	Response based Maintains data integrity	No or low requirements on delay Maintains data integrity
<i>Example</i>	Speech, video telephony, games	Music or video streaming	Web browsing, Chat	E-mail download, social networks

Service classes (2)

- **Error tolerance and delay (latency):**

Error tolerant	Conversational voice and video	Voice messaging	Streaming audio and video	Fax
Error intolerant	Telnet, interactive games	E-commerce, WWW browsing,	FTP, still image, paging	E-mail arrival notification
	Conversational (delay $\ll 1$ sec)	Interactive (delay approx 1 sec)	Streaming (delay < 10 sec)	Background (delay > 10 sec)

Summary network architectures

- **The main components of a mobile network are:**
 - The user equipment (UE)
 - The access network (AN)
 - The core network (CN)
- **A modified protocol stack is used in mobile systems to handle special functions compared to other computer networks**
- **Some basic network functions of a mobile network are:**
 - Network choice
 - Location update
 - Call/session setup
 - Handover
- **Services and applications are divided into different traffic classes dependent on the error tolerance and latency requirements**